

ORDER CODE : 059
ISSUE 1 : SEPTEMBER, 1981
ISSUE 2 : APRIL, 1982

TECHNICAL SERVICE MANUAL
for
HF SSB TRANSCEIVER TYPE 7727-TB

HEAD OFFICE
ENGINEERING & MANUFACTURING

Codan Pty. Ltd.,
Graves Street,
Newton, South Australia, 5074
Telephone:
National (08) 337 7000
International +61 8 337 7000
Telex: AA88155
Telegrams: Codan, Adelaide

INTERNATIONAL
MARKETING OFFICE

Codan Pty. Ltd.,
4 Help Street,
Chatswood, N.S.W. 2067
Australia
Telephone:
National (02) 419 2397
International +61 2 419 2397
Telex: AA22631
Telegrams: Codan, Sydney

CONTENTS

1. GENERAL INFORMATION
 - 1.1 Introduction
 - 1.2 Specifications
 - 1.3 Options and Accessories
 - 1.4 Definitions

2. BLOCK DIAGRAM

3. BRIEF DESCRIPTION
 - 3.1 General
 - 3.2 Transmit
 - 3.3 Receive

4. TECHNICAL DESCRIPTION
 - 4.1 General
 - 4.2 Switching
 - 4.2.1 Switching Voltages
 - 4.2.2 Channel Selection
 - 4.3 Receive
 - 4.3.1 Broadcast Filter
 - 4.3.2 RF Amplifier
 - 4.3.3 Balanced Mixer
 - 4.3.4 1st IF Amplifier
 - 4.3.5 Noise Limiter
 - 4.3.6 Crystal Filters
 - 4.3.7 2nd IF Amplifier
 - 4.3.8 AM Detector
 - 4.3.9 SSB Demodulator
 - 4.3.10 AGC Amplifier
 - 4.3.11 Mute
 - 4.3.12 Audio Amplifier
 - 4.4 Transmit
 - 4.4.1 Microphone Amplifier
 - 4.4.2 Carrier Oscillator
 - 4.4.3 Balanced Modulator
 - 4.4.4 Filter Selection
 - 4.4.5 Transmit IF Amplifier
 - 4.4.6 Channel Oscillator

Contents

4.4 (cont.)

- 4.4.7 Clarifier
- 4.4.8 Balanced Mixer
- 4.4.9 Transmit RF Amplifiers
- 4.4.10 Channel Selection

4.5 PA and Filters

- 4.5.1 PTT Control
- 4.5.2 Gain Control Amplifier & Input Stage
- 4.5.3 Driver Stage and Driver Bias
- 4.5.4 Output Stage and Bias Regulator
- 4.5.5 Receive/Transmit Lamp Driver
- 4.5.6 PA Filters
- 4.5.7 ALC Circuits
- 4.5.8 Typical PA Voltages

5. MAINTENANCE

- 5.1 Fault Finding
- 5.2 Transmitter Precautions
- 5.3 Probe Precautions
- 5.4 Lamp Replacement
- 5.5 Replacement of PA Components
- 5.6 Replacement of PA Output and Driver Transistors
 - 5.6.1 Driver Transistors
 - 5.6.2 Output Transistors

6. CHANNEL ADDITION

- 6.1 Introduction
- 6.2 Preliminary
- 6.3 RF Coil Components
- 6.4 Channel Oscillator
- 6.5 Channel Crystals
- 6.6 Compensating Capacitors
- 6.7 P.A. Filters
- 6.8 Two Frequency Simplex
- 6.9 Test Equipment Required
- 6.10 Adjustments - General

Contents (cont.)

6.11 Adjustments - Transmitter

6.12 Adjustments - Receiver

7. PRE-SET ADJUSTMENTS

7.1 Test Equipment Required

7.2 Preliminary

7.3 Voltage Regulator

7.4 Carrier Oscillator

7.5 Channel Oscillators

7.6 RF Alignment

7.7 IF Alignment

7.8 PA Bias

7.9 ALC

7.10 Receiver Performance Checks

7.11 Transmitter Performance Checks

7.12 Mute Adjustment

7.13 Emergency Call Assembly Adjustments

8. PARTS LISTS

8.1 General Information

8.1.1 Ordering Information

8.1.2 Component Substitution

8.2 Parts List Index

8.3 Parts Lists

9. DRAWINGS

9.1 List of Drawings

SSB TRANSCEIVER
TYPE 7727-TB

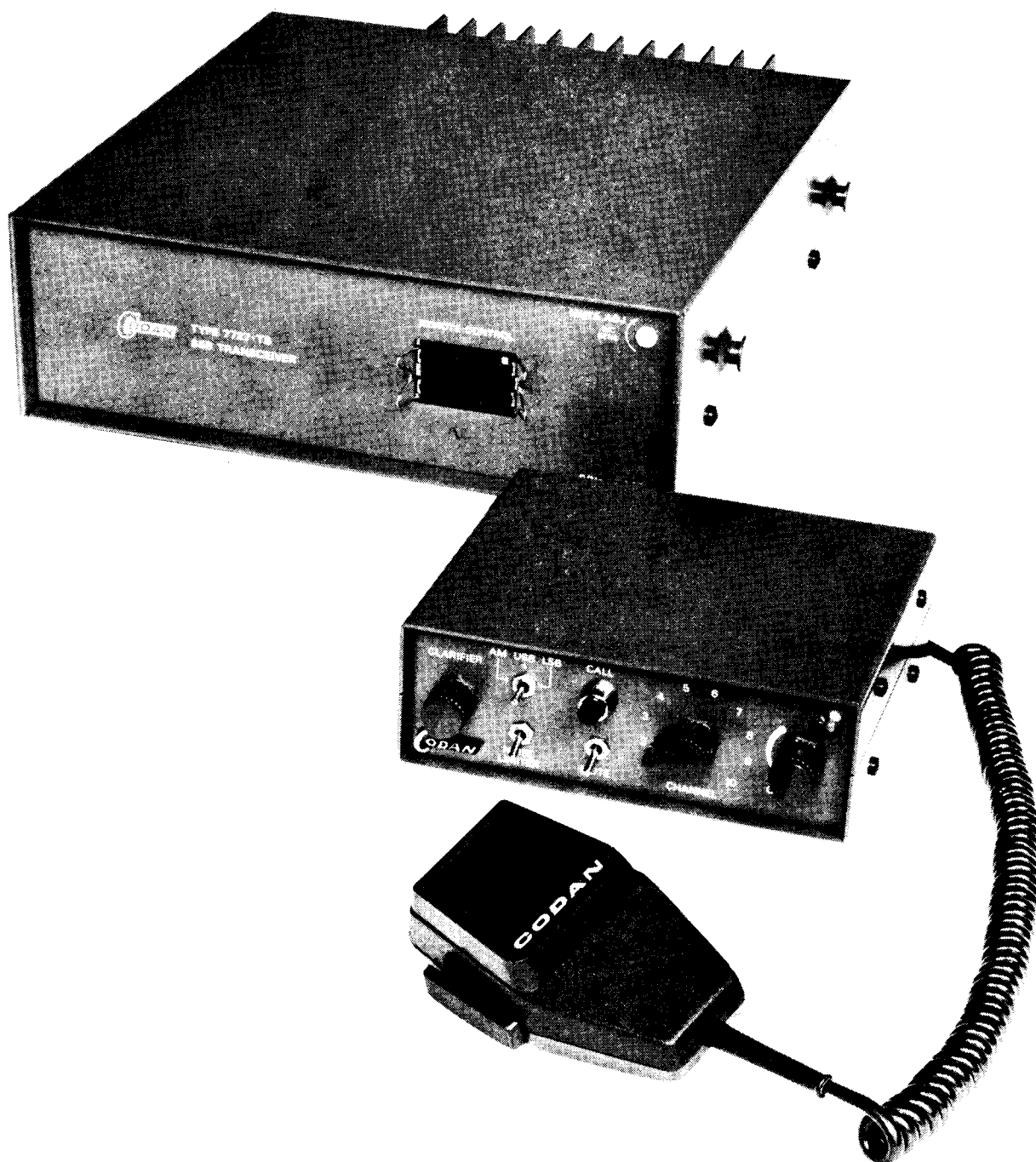

1. GENERAL INFORMATION

1.1 Introduction

The 7727-TB SSB transceiver is a fully solid state 100W PEP unit for fixed or mobile use in land services, using a 12V or 24V dc power source. A range of options and accessories are available to cater for different applications. Special versions are available or can be manufactured where the standard equipment does not meet the operational requirements.

This manual is divided into sections covering the Specifications, Brief Description, Detailed Technical Description, Maintenance and Adjustments, Parts Lists and Circuit and Layout Diagrams. Each page of text has an indication of the contents on the top outer corner for easy reference. Special versions are not covered by this handbook.

Installation information and operating instructions are contained in the Installation Manuals and operating instruction cards supplied with each transceiver.

To minimise the chance of misunderstandings all correspondence must include the type and serial number of the transceiver and the issue number and latest amendment number of the handbook where this is referred to.

Additional unbound circuit diagrams are included at the rear of this manual. If required, full size prints (paper size A1 & B) may be purchased separately.

Specifications

1.2 Specifications

1.2.1 General

Design figures are quoted with limit figures in brackets, all tests are carried out at 13.6V or 27.2V dc input (as appropriate). Specification is subject to change without notice.

Frequency range:	2...16 MHz
Crystal capacity:	10
Channel capacity:	10 single frequency simplex, or 5 two frequency simplex, or any combination that does not exceed the crystal capacity.
Operating modes:	Single sideband (A3J) USB or LSB
Frequency stability:	±50 Hz, in range 5...55°C ±60 Hz, in range 0...60°C with ±10% input voltage variation
Controls:	Power ON/OFF and VOLUME Mode: SSB, TUNE, *LSB/USB CHANNEL SELECT * CLARIFIER * EMERGENCY CALL (RFDS) NOISE LIMITER ON/OFF MUTE ON/OFF (* options)
Indicators (illuminated)	Power/Transmit
Connectors:	Rear (head) Microphone Front Remote Control Socket Rear Antenna Power input Extension LS (Optional) Antenna Select (Optional)
RF input/output impedance:	50Ω nominal. The transceiver will operate with a load impedance producing a VSWR of less than 2:1.
Input voltage:	Nominal 13.6V or 27.2V dc. The transceiver will operate with input voltages between 11V and 15V or 22V and 30V positive or negative ground, reverse polarity protection is provided.
Power Consumption:	Receive, 300mA no signal Transmit, A3J average 5A or 3A A3J two-tone 11A or 6A (nominal)

Specifications

1.2.1 (cont.)

Environmental:

Ambient Temperature °C	-10 to +30	+30 to +60
Relative Humidity %	above 95	from 95 at 30°C to max. 50 at 60°C
Atmospheric Pressure	645 millibars (3600 m above sea level) with maximum temperature derated by 1°C for every 330 m above sea level.	

Cooling:

Convection

Size and Weight:

	Transceiver	Control Head
Width	270 mm	160 mm
Height	95 mm	55 mm
Depth	325 mm	150 mm
Weight	4.5 kg	-

1.2.2

Receiver

Type:

All transistor, single conversion superheterodyne.

IF:

1650 kHz

Sensitivity:

An aerial emf of less than 0.5 μ V from a 50 Ω source will produce a signal plus noise/noise ratio of 10dB (A3J).

Maximum input:

10V rms.

Selectivity:

A3J, better than 70dB (60)
-1, +5 kHz
better than 6dB (8),
300...2800 Hz.

Image Rejection:

Better than 60dB (55).

Spurious Signal Rejection:

Better than 65dB (60).

* Cross Modulation:

A signal 75dB (65), above a signal producing a 10dB S+N/N ratio modulated 30% and removed at least 20 kHz from the wanted signal will produce an increase in receiver noise of less than 3dB.

* Intermodulation:

To produce a third order inter-modulation product equivalent to a wanted signal producing a 10dB S+N/N ratio, two unwanted signals greater than 30 kHz removed from the wanted signal must have a level greater than 65dB (60) above the wanted signal.

Specifications

1.2.2 (cont.)

- * Blocking: A signal 85dB (70) above a signal producing a 10dB S+N/N ratio and removed at least 20 kHz from the wanted signal will cause a change in output level of the wanted signal of less than 3dB.
- AGC: Less than 3dB (6) variation in output for signal strength variations between 3µV and 100mV.
- AF Power and Distortion: 2.5 Watts at less than 5% THD.

AF Response: 300...2800 Hz, $+0$
 -3 dB

Clarifier Range

- CAN: Nominal $\pm 0.0007\%$ of SCF or ± 25 Hz whichever is greater, continuously variable.
- CAW: ** Nominal $\pm 0.003\%$ of SCF, continuously variable.

** Export Only

- * These parameters are measured in terms of Australian Department of Communications Specification RB209, RB209-0.

1.2.3 Transmitter

- Type: All solid state including power stages.
- Power Output: SSB (A3J): 100 Watts PEP ± 1 dB.
- AF Response: Overall response of transmitter rises at approximately 6dB/octave from 300 Hz...2800 Hz. At higher frequencies cut-off is very rapid.
- Harmonic Emissions: 55dB (45) below PEP.
- Spurious Emissions: Spurious emissions (not harmonics) separated from the carrier by more than 20 kHz, 50dB (43) below PEP.
- Carrier Suppression: 50dB (40) below PEP.
- Unwanted Sideband: 45dB (43) below PEP.
- Intermodulation Products: 33dB (31) below PEP.

Specifications

1.2.3 (cont.)

ALC Range:	30dB change in input signal produces less than 1dB change in output.
Clarifier Range:	As for Receiver Specifications above NOTE: Only available when Option CB fitted.
Microphone:	Rocking armature, with push-to-talk fitted to case.

Options and Accessories

1.3 Options and Accessories

(a) Options

<u>Code</u>	<u>Option</u>
L	LSB
U	USB
LU	LSB in addition to USB
BA	One single frequency simplex channel (specify frequency).
BB	One two frequency simplex channel (specify transmit and receive frequencies).
CAN	Clarifier, narrow, receive only.
CBN	Clarifier, narrow, transmit and receive.
CAW	Clarifier, wide, receive only.
CBW	Clarifier, wide, transmit and receive.
E	Emergency Call Facility.
AS	Antenna selector.
PL	Extension loudspeaker socket.
PB	Balanced Audio Output Low Z or 600 Ω .
N	Noise Limiter.
Q	Mute facility.

(b) Accessories

<u>Code</u>	<u>Accessory</u>
059	Technical Service Manual
030 400/1	Installation Manual Centre fed dipole antenna.
402	End-fed broadband antenna system complete with 30 metres of RG58 cable and connectors. Range 2...10 MHz.
403	End-fed long wire antenna kit (specify frequencies), requires a Type 7208 Antenna Tuner.
600	Telephone handset with PTT.

1.3 (b) (cont.)

601	Desk microphone with PTT.
608	Extended Local Control head, Desk mounting
107	Vehicle mounting kit.
306/1 to 5	Helical whip antennas 1.83 metres in length, suffix number indicates number of frequency taps provided.
304	Base loaded 2-frequency mobile whip antenna, 3.35 metres in length with automatic (relay switched) frequency selection. Supplied with base mounting assembly. Requires option AS to be fitted.
301	Spring mounting base for all Code 300 series antennas - supplied with UHF type coaxial connector.
401	"Quick-to-erect" dipole antenna kit type LW/5 supplied with 10 metres of RG58 cable and connectors.
501X	AC Power Supply Type 7113 supplied with inter-connection cable.
603	Extension loudspeaker.
704	Interference Suppression Kit.

(c) Standard Accessories

(i) Supplied with each transceiver,

Hand microphone with PTT switch,
 12V or 24V dc power cable,
 Installation manual.

609 Extended Local Control head, Vehicle mounting

Definitions

1.4 Definitions

The following abbreviations may be encountered in this handbook.

ac	Alternating current	PCB	Printed Circuit Board
AF	Audio frequency	PEP	Peak envelope power
AGC	Automatic gain control	PL	Plug
ALC	Automatic level control	PTT	Push-to-talk
AM	Amplitude modulation	R	Resistor
C	Capacitor	RF	Radio Frequency
CH	Channel	rms	Root mean square
CRO	Cathode-ray oscilloscope	RV	Resistor, variable
CW	Continuous wave	Rx	Receive or receiver
D	Diode	SCF	Suppressed carrier frequency
dc	Direct current	SK	Socket
DSB	Double sideband	S+N/N	Signal plus noise, over noise
emf	Electro-motive Force	SSB	Single sideband
F	Fuse	SW	Switch
FL	Filter	T	Transformer
IC	Integrated circuit	THD	Total harmonic distortion
IF	Intermediate frequency	TP	Test point
L	Inductor	TS	Tag strip
LP	Lamp	Tx	Transmit or transmitter
LPF	Low pass filter	USB	Upper sideband
LS	Loudspeaker	V	Transistor
LSB	Lower sideband	VSWR	Voltage standing wave ratio
PA	Power amplifier		
+ve	positive		
-ve	negative		

A3	AM, carrier plus upper and lower sidebands
A3H	Compatible AM, carrier plus one sideband only
A3J	SSB, suppressed carrier

CLARIFIER	A device to finely adjust the frequency of the received audio.
MODULATOR	A device used to vary the RF carrier at an AF rate.
DEMODULATOR	A device to detect the AF variations of a RF carrier.
MIXER	A device to mix two RF signals and produce the sum and difference frequencies (one of which is selected by a tuned circuit).

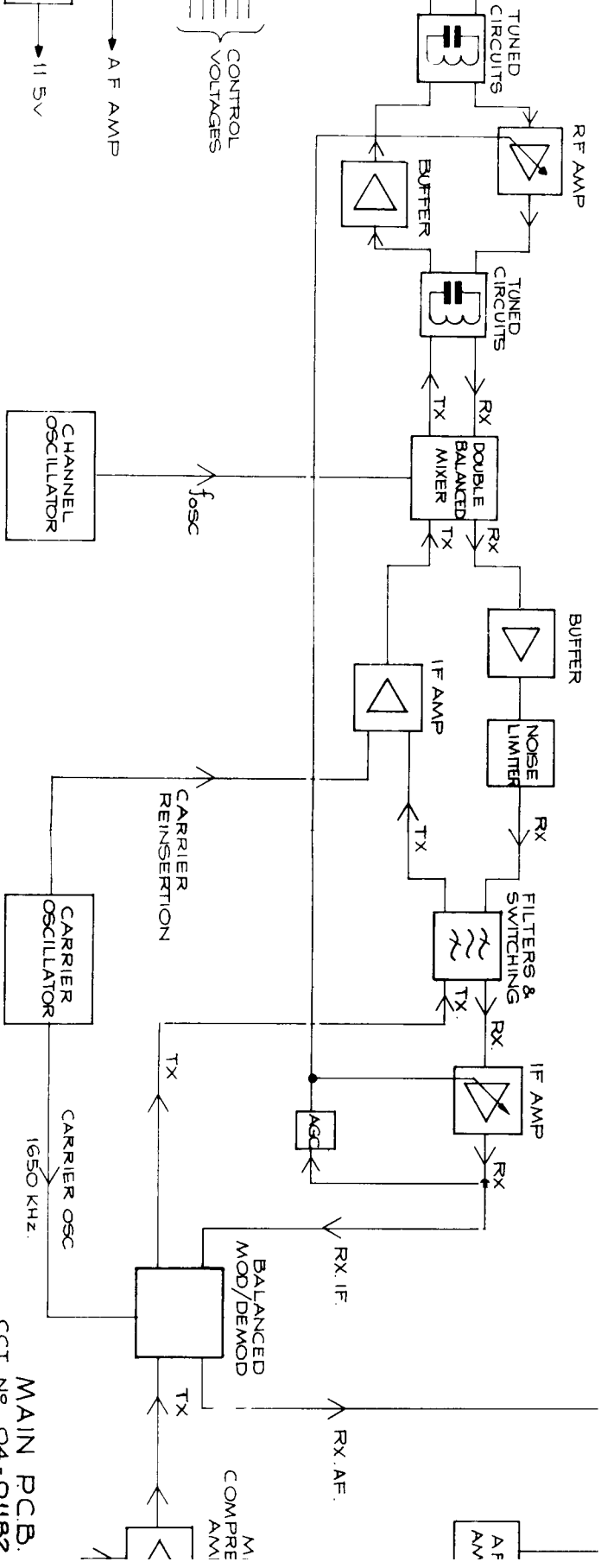

MAIN PCB.
CCT. No 04-01182

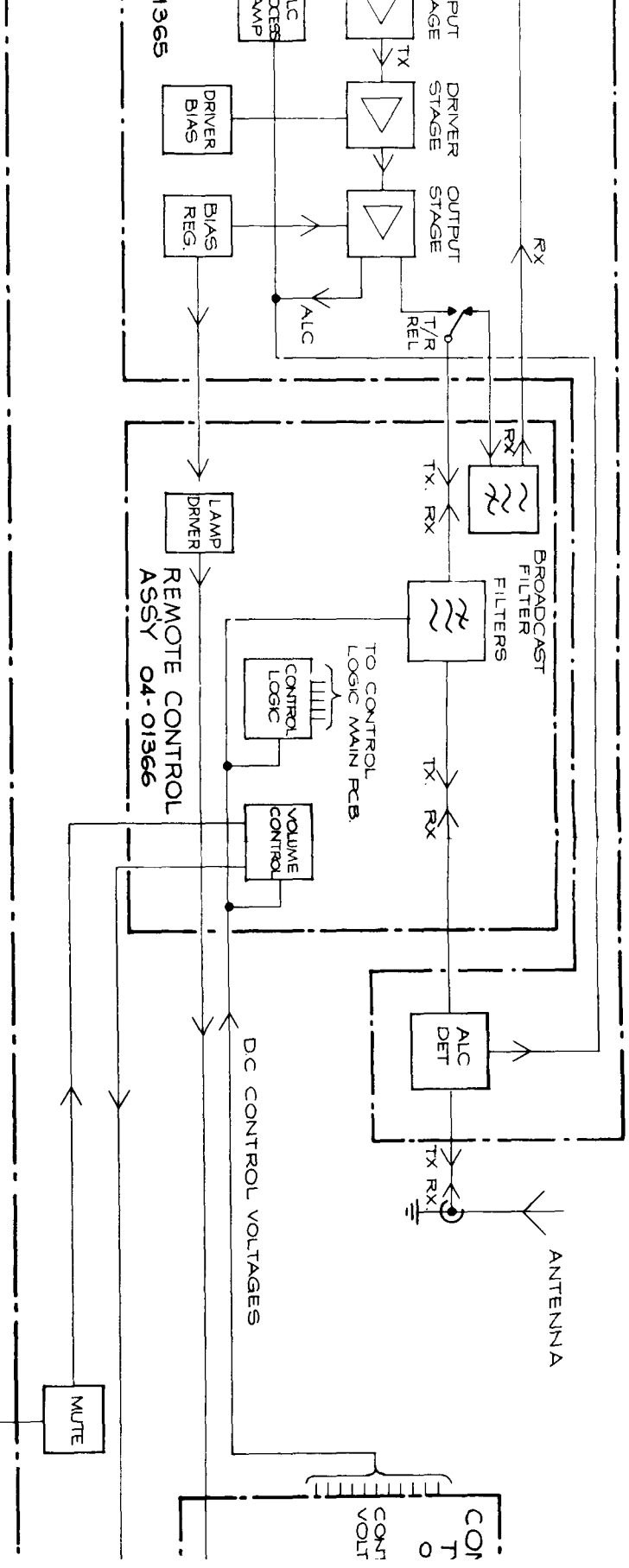

365

LC ACCESS WMP

DRIVER BIAS

BIAS REG.

REMOTE CONTROL ASSY 04-01366

DC CONTROL VOLTAGES

MUTE

CON T 0 CONT VOLT

PUT

DRIVER STAGE

OUTPUT STAGE

ALC

RX

LAMP DRIVER

TO CONTROL LOGIC MAIN PCB

VOLUME CONTROL

ALC DET

ANTENNA

ANTENNA

CON T 0 CONT VOLT

TX

TX

TX

T/R REL

RX

TX

BROADCAST FILTER FILTERS

TO CONTROL LOGIC MAIN PCB

TX

RX

TX

RX

TX

RX

TX

RX

TX

RX

CON T 0 CONT VOLT

3. BRIEF DESCRIPTION

3.1 General

This description should be read in conjunction with Block Diagram 03-00361.

The 7727-TB uses the same frequency conversions in both the transmit and receive modes, therefore many circuits are common to both modes of operation. Signal routing is determined by switching voltages according to the mode selected and the state of the microphone PTT button.

3.2 Transmit

The audio signal is amplified and levelled in the Microphone Compressor amplifier stage and fed to the Balanced Modulator. The Carrier oscillator provides the 1650 kHz IF carrier for the Balanced Modulator, where it is modulated by the audio signal to produce a double sideband (DSB) signal centred on 1650 kHz, the carrier being suppressed. The DSB signal is then fed to a SSB filter which passes only one sideband, either upper or lower (USB or LSB), the resultant SSB signal being fed to the IF amplifier.

In the IF amplifier, carrier may be added to facilitate antenna tuning.

The amplified IF signal then passes to the Double Balanced Mixer where it is mixed with the Channel Oscillator output to produce the sum and difference frequencies. These products are then fed to the tuned RF amplifiers which remove the sum ("image") frequency and any unwanted products generated in the previous circuitry. The remaining difference frequency is then fed to the PA.

The PA has four stages of amplification consisting of a Gain Control Amplifier, followed by a class A and two Class AB stages. Each class AB stage is biased from independent temperature compensated bias supplies. The bias supply of the output stage is also used to drive a lamp to indicate when RF power is being developed.

The signal from the output stage is fed to the load via a switchable low pass filter, which removes harmonics generated in the PA so only the wanted signal reaches the antenna.

The ALC/SWR detectors provide a control signal which is processed, amplified and used to adjust the gain of the Gain Control Amplifier. The ALC action ensures that the maximum possible power, within the ratings of the transceiver, is delivered to the antenna over a wide range of antenna loading without degradation of the quality of the output signal.

3.3 Receive

The RF signal from the antenna passes via the ALC detectors (inoperative in receive) to the PA Filter. The signal is then directed by the T/R relay through the Broadcast Filter to the Main PCB. The signal is then coupled via the RF tuned circuits and RF amplifier to the Double Balanced Mixer. The tuned circuits provide attenuation of unwanted signals, particularly the image frequency.

The Double Balanced Mixer mixes the Channel Oscillator with the signal to produce a signal at the IF (1650 kHz). This is amplified and then fed to the noise limiter prior to being filtered by the Crystal Filter.

The noise limiter is designed to suppress impulse noises such as motor vehicle ignition noise. The limiter operates by "breaking" the IF signal path for the duration of the noise pulses.

The Crystal Filter provides a high degree of selectivity, passing only the wanted signal on to the tuned IF amplifier. Following amplification the signal is peak detected by the AGC detector which controls the gain of the RF amplifier and the tuned IF amplifier.

The IF signal is mixed with the carrier oscillator in the Balanced Mod/Demod in the SSB mode to produce the audio signal.

The audio signal is then passed through a Mute circuit which breaks the audio signal path when there is no signal present. The signal is then fed via a Power Amplifier to the loudspeaker.

4. TECHNICAL DESCRIPTION

4.1 General

The following description is divided into sections:

- 4.2 Switching
- 4.3 Receive
- 4.4 Transmit
- 4.5 PA

As the MAIN PCB is used in both the 7515 and 7727-B/7727-TB transceivers, some sections of the following text may appear irrelevant, since the 7515 has provision for AM whereas the 7727-B/7727-TB does not.

The circuit diagrams referred to in the text are:

- 04-01182 MAIN PCB
- 04-01365 PA & CHASSIS
- 04-01366 10 CHANNEL 7727-TB CIRCUIT DIAGRAM

4.2 Switching4.2.1 Switching Voltages

All switching voltages are designated by a letter tabulated below. The derivation of each voltage and its function follows the table.

<u>Designation</u>	<u>Voltage state (with set ON)</u>
A	Unregulated supply, continuous.
B	Regulated supply, continuous.
C	Positive on receive (gnd on Tx).
D	Positive on transmit (gnd on Rx).
E	Positive only on AM receive.
F	Positive only on SSB receive.
G	Positive except during AM receive.
H	Positive except during AM transmit.

A : The unregulated supply is fed to:-

- (a) The PA PCB
- (b) The Main PCB for the AF amplifier and Regulator.
- (c) The Remote Control PCB to the Lamp Driver and Filter Select Relays.

B : is derived from A, via the regulator and is fed to:-

- (a) Channel oscillator and amplifier via 2R66.
- (b) Clarifier via 2R69.
- (c) Channel oscillator selector, via 2R46 and the Channel Energise Pins.
- (d) 2V25 to provide C on receive.
- (e) Balanced modulator-to-filter gates 2D57 and 2D58, and the inhibit gate 2V21, via 2R115.

C : is derived from B at 2V25 which is held conducting by 2R127 grounded by D. C is grounded during transmit, (D high turns 2V25 off and 2V26 on). C is fed to:-

- (a) 1st IF amp via 2R37.
- (b) 2nd IF amp and AGC amp.
- (c) RF amp via 2R13.
- (d) Balanced modulator-to-filter gate 2V21 via 2R114 to inhibit the gate during receive.
- (e) Channel Selector on Remote Control PCB for two frequency simplex receive channels.

4.2.1 (cont.)

- (f) Transmit/receive gates (2D19, 2D4, 2D5) on the RF tuned circuits.
- (g) Clarifier steering diode, 2D50.
- (k) Noise Limiter via 2R210 and 2R206.

D : is produced directly from B when the PTT button is operated, D is grounded during receive, (2V27 held on by C via 2R129). D is fed to:-

- (a) 3V7 via 3R17 to provide power to the P.A. and drive the Transmit/Receive Relay.
- (b) AF amp via 2D65 as an inhibit.
- (c) Transmit IF amp via 2R84.
- (d) Transmit RF amp via 2R23.
- (e) Clarifier steering diode 2D47.
- (f) Receive inhibit gate 2D2 and 2D4.
- (g) 2D55 to produce G.
- (h) Channel Selector on Remote Control PCB for two frequency simplex transmit channels.

E : is derived from B, on the Remote Control PCB via SW2 and V8

It is therefore positive when FL2 is required.

F : is derived from C, via a link on the MAIN PCB, and is fed to :-

- (a) 2D53 to produce G.
- (b) 2D54 AM detector diode (disable).

G : is received from D, via 2D55 during transmit, or F, via 2D53 during SSB receive.

It is therefore positive except during AM receive and is fed as supply to the 1650 kHz carrier oscillator.

H : is derived from B, via D18 and R21

It is therefore positive except for "TUNE" and is fed to the carrier re-insertion gate 2V24 via 2R125, as an inhibit.

The switching table should be kept to hand when reading the Technical Description.

4.2.2 Channel Selection

Single Frequency Simplex

The B voltage on the Remote Control PCB is fed to the selected Channel Energise pin and supplies:-

- (a) The desired channel crystal,
- (b) The desired channel RF coil gates.

SW1 also selects the appropriate PA Filter via diode gates.

Example

Select Channel 2 with the Channel Switch. The B supply from the Channel Energise pin will connect Channel 2 crystal to the oscillator circuit via R48 and D37. The Channel 2 AE coil will be enabled via the internal resistor, L3 and

- (a) D8,D5,R13,R9 to C on transmit,
- or (b) D9,L8,R10, to D, and
D8,D2,T1 and R3 on receive.

Channel 2 RF coil will be enabled via the internal resistor, L12, and

- (a) D22,R25,L10 and
- (b) D23,R26,T3 for transmit and receive.

Two Frequency Simplex

In this mode, different channel frequencies are used for transmit and receive. During receive, the Channel Energise pin fed from C (+ve Rx) selects the receive channel crystal and RF coils. During transmit the Channel Energise pin fed from D (+ve Tx) selects the transmit channel crystal and RF coils.

4.3 Receive

4.3.1 Broadcast Filter

Fitted on the PA Filter PCB is a high pass filter designed to eliminate interference from broadcast stations below 2 MHz. The antenna is connected to the receiver via the PA filter, relay contact A1 and this filter.

4.3.2 RF amplifier

The received signals are fed in via T1. Diodes D1 and D3 placed back to back across T1 secondary to prevent a severe overload from damaging V3. The signal is passed via gate D2 to the selected RF coil and via C17 to the base of V3. The signal is amplified by the forward gain controlled RF amplifier V3 and fed via D19 to the selected RF coil and then via R26, C30 to the balanced mixer input at T3.

4.3.3 Balanced Mixer

T3 is connected across diode ring D32-35 which is in turn connected across T4. The centre tap of T4 is connected to the channel oscillator so the required mixer product, centred on 1650 kHz, is developed across the tuned side of T4.

4.3.4 1st IF amplifier

The IF signal from T4 is passed via C33 and R32 to the base of V8, the first stage of the feedback pair V8 and V9. The dc feedback via R38 and ac feedback via C36, R39 and R40 set the stage gain. The output signal from V9 collector is fed via the Noise Limiter to the Crystal Filters.

4.3.5 Noise Limiter (Option N)

A balanced series gate is formed by D204, D205 and T201, T202. In the absence of noise pulses D204 and D205 are forward biased by R205 thus forming a low impedance path through the gate and permitting normal receiver operation. A reference voltage for the cathodes of D204 and D205 is provided at the centre tap of T202 by R215 and zener diode V204.

The signal (containing noise pulses) is fed to the base of V203, the collector load of which is tuned by L201 and C206 to the 1650 kHz IF. The parallel tuned circuit at the input of V203 (L202 and C210) is also tuned to 1650 kHz to reject any channel oscillator signals which may be present at the output of the balanced mixer. Both the base and collector tuned circuits operate at low "Q" thus avoiding the need for adjustment.

The output of V203 is fed via C207 to the base of V202. The resultant signal is clamped to ground by D203 such that only the positive going peaks of the signal and noise pulses are amplified by V202.

4.3.5 (cont.)

Transistor V202 serves a dual purpose by means of two collector circuits isolated from each other by D202.

- (a) The positive going noise pulse at the base of V202 produces negative going pulses across R205 which results in D204 and D205 being reverse biased thus opening the gate for the duration of the noise pulse. The RF is bypassed by C212 such that only the envelope of the noise pulse remains.
- (b) The negative going signal and noise pulses at the collector of V202 charge C202 via R204. A long time constant is chosen so that the voltage fed to the base of V201 corresponds to the average level of the signal and is not affected by narrow noise pulses. This voltage is amplified by V201 and is used to control the gain of V203. The AGC voltage derived in this manner always maintains the gain of V203 so that over a very wide range of signal input levels, only noise pulses will be of sufficient amplitude to operate the gate. Divider R201 and R202 set the "no signal" AGC voltage at the base of V203.

The noise limiter is disabled by grounding the base of V201 via R203. This turns V201 hard on effectively connecting the AGC line to rail. The gain of V203 is reduced so that its output is insufficient to drive V202.

4.3.6 Crystal Filters

The SSB filters are designed to pass one sideband only, 300 Hz to 2.8 kHz either side of 1650 kHz. They attenuate the carrier frequency 20dB and the unwanted sideband approximately 55dB. The AM filter passes both sidebands plus carrier, 3 kHz both sides of 1650 kHz and can therefore pass A3 and A3H signals.

4.3.7 2nd IF amplifier

V17 is a forward gain controlled amplifier and the amplified signal is developed across the tuned primary of T5. V18 is a conventional amplifier and accepts signals from T5 via C65, the amplified signal is then developed across the tuned primary of T6.

4.3.8 AM detector (when fitted)

D54 is a conventional diode envelope detector fed by T6, the AF voltage appearing across the diode load R101, R130 and R138. C103 couples the AF signal to the VOLUME control. D54 is back-biased in the SSB mode by the G rail via R99 and R100, (derived from the F rail via D53). In the AM Mode the carrier oscillator is inhibited.

4.3.9 SSB demodulator

IF signals from T6 secondary are fed via R98, C74 and T7 (D58 gate is inhibited) to the balanced modulator/demodulator to be mixed with 1650 kHz from the carrier oscillator. The demodulated AF signal from the diode ring is fed via C76 and C103 to the VOLUME control. C75 limits the frequency response of the demodulator.

4.3.10 AGC amplifier

The IF signal from T6 in the receive mode is fed via R102 to the base of V19, which will conduct only on the positive half cycles of signals which exceed 1.2V pp. The collector current of V19 charges C71 and also C72 via R103. The voltage across these capacitors feeds the base of V20. The AGC line, in the absence of a signal is held at approximately 2.2V by the voltage divider R110 and R109; this produces the desired static gain in both controlled stages. As the signal increases, the voltage across C71 increases and turns on V20 to increase the AGC voltage developed across R109.

The AGC voltage is applied to the RF amplifier and to the first stage of the 2nd IF amplifier. The AGC loop gain is high and the IF output from T6 is held virtually constant for a 100dB change in input signal.

The attack time is very fast determined primarily by R106 and C71. The release time is controlled by a double time constant of approximately 220mS and 2.2 Secs. Wanted signals normally have time to charge C72 via R103 and when the signal ceases, C72 discharges via R103 and R105 to hold V20 conducting for the longer release time. Short static pulses only have time to charge C71 (but not C72), and discharge quickly via R105 resulting in a short release time. In this way the receiver is desensitised only for a minimal time due to static, but on wanted signals the longer time constant prevents an upsurge of background noise between words and sentences.

4.3.11 Mute

The FET 9V5 is in series with the audio path before the audio amplifier and is used as a switch, governed by the voltage at its gate.

The audio signal is buffered and limited prior to being fed to the active bandpass filters, one centred on 815 Hz and the other 2.35 kHz. The 815 Hz filter has a further amplifier, 9IC1c, to allow a wide range of adjustment of sensitivity.

The outputs from the filters are rectified and filtered by 9IC3a and 9IC3b, and the D.C. levels compared by 9IC3c. The outputs of 9IC3c and 9IC1 are then 'OR'ed and amplified by 9IC3d which in turn feeds the gate of 9V5.

4.3.11 (cont.)

When there is no voice present in the audio, the noise signal is generally wide band, so the output from the active filters/rectifiers are equal (this may be adjusted by the sensitivity control). This implies the output from 9IC3c will be 0V and from 9IC3d is +10.5V. This turns 9V5 OFF. When voice is present, more energy exists in the 800 Hz area, so the outputs from the filters/rectifiers are no longer equal, the output from 9IC3b being more positive. Thus the output from 9IC3d drops to 0V turning 9V5 ON. The mute may be disabled by grounding the input of 9IC1a, permanently turning 9V5 ON.

4.3.12 Audio amplifier

The DC supply derived from the A rail (via relay contact B2) is always on. The fuse F1 is fitted only as a precaution, to guard against an accidental short circuit on the A rail.

AF signals are fed to the input of IC2 via the mute and the dc volume control on the Remote Control PCB. The dc volume control is used to enable extended control over up to 100 metres of cable. This consists of a two stage FET (Field Effect Transistor) attenuator. The first stage of attenuation is R30 to V12 and the second stage is R29 to V11. The resistance of the FET channels, and hence the attenuation and volume level, is controlled by the voltage on the FET gates. This control voltage, filtered by R27 and C40 to remove any possible interference, is derived from the volume control in the following manner.

A voltage divider across the supply is formed by R24, R25 and the volume control. The voltage at the wiper is applied via R27 to the FET gates. R24 is selected so that at maximum setting of the volume control, the circuit just begins to attenuate the signal, thus avoiding a dead-band in the volume control. R26 provides a near linear dB law for the control.

AF signals from the volume control are fed via R139 and C93 (which with C92 limits the frequency response) to the input of IC2. The amplified output is developed across T8 primary, the amplifier frequency response is limited by the feedback capacitors C99 and C97 and the gain is set by C95 and R142. The loudspeaker is only connected when the microphone plug is inserted into SK11 and is fed from the secondary of T8. During transmit, the D rail fed via D65 and R140 causes V33 to conduct and inhibit the AF input to IC2.

4.4 Transmit

4.4.1 Microphone Amplifier

The microphone input is fed to the Main PCB at SK6/1 and 2. The common mode choke, T9, and capacitor C85, provide further rejection of R.F. before being fed to the 748 operational amplifier, via C86. The gain of IC1 is defined by the ratio of R133 to R132 and high frequency roll-off is provided by C88 and C145. The dc output voltage is set at +5.5V through R131 to the non-inverting input of IC1. When the output voltage rises to 7.5V due to audio peaks, V28 turns on and charges C90.

The FET, V29, is connected as a voltage controlled resistor and is part of a variable attenuator formed by R169 and R131. With no audio present, the gate is held at -5.5V relative to the source and drain, so V29 represents a very high resistance and the attenuator provides minimum attenuation. When the gate voltage is brought closer to the source voltage, the drain-source resistance drops giving greater attenuation. As the gate voltage is derived from C90, the FET resistance only drops when the output from IC1 exceeds +7.5V. This FET attenuator thus provides the function of an audio compressor, the audio output limited to 4V pp. R136 and R137 provide a fast attack-slow release characteristic, and the reference voltages are provided by R166, R167, R168, C87 and V39.

In the AM mode, V32 is saturated via R150, thus connecting a shunt, R151, across the output of the microphone amplifier. The value of R151 is chosen to set the output of the main PCB in the SSB and AM modes to be equal.

The audio signals also appear across the volume control but the AF amplifier is in-operative during transmit. The G rail voltage fed via R99 and R100 back bias D54 to provide isolation between the input and output of the balanced modulator.

4.4.2 Carrier Oscillator

The frequency of the 1650 kHz crystal oscillator V22 is adjusted by C79a, b and c in the capacitor feedback divider network (with C77 at 1/3rd capacity). Fine frequency trimming is then made by C77 alone. V22 is biased by R119, V38 and R120, with C78 and C79 providing the feedback necessary for oscillation.

The RF output is buffered by V23 emitter follower and fed via R122 and C80 to the balanced modulator. C82 adjusts the carrier re-insertion level fed out via C81 in the AM transmit mode. In other modes, V24 is held conduction to prevent carrier re-insertion (by H via R125). The carrier oscillator is supplied from the G rail and is therefore not operated in the AM receive mode.

4.4.3 Balanced Modulator

The carrier oscillator output is fed to the junction of R116 and R117 connected across two arms of the diode ring D59-D62. The diode ring is switched at carrier frequency, thus modulating the audio signal across the opposite arms of the ring. A double sideband (DSB) signal (1650 kHz + AF and 1650 kHz - AF) is developed across the primary of T7, with a carrier suppression of typically 30dB.

During transmit the balanced modulator-to-filter gate is enabled by the B rail fed via R115, D58, R98, T6 to ground and via D57, R113 and L18 to ground. (V21 is held non-conducting by the C rail at ground potential). The DSB signals pass via C74, D58, D57 and R113 to the filter selection network.

4.4.4 Filter Selection (when fitted)

With the E rail floating, V34 is held off by R160, so the collector of V34 is held high via R163. Therefore D68 and D71 are off and D69 is on resulting in the filter FL2 being isolated from RF. V35 is held on by R159, which turns D67 and D70 on and D72 off, resulting in FL1 being in the RF path. Thus, with the E rail low, FL1 is on, FL2 is off. Taking the E rail high inverts the result. C108 and C107 provide optimum operating conditions for the filters.

4.4.5 Transmit IF amplifier

The signal from the SSB filter is fed via C55 and R83 to the emitter of V16. V16 operates in the common base configuration for IF signals and in the common emitter configuration for the re-inserted carrier in the AM mode. Resistive divider R80, R81 and R82 set the operating point for V16 and hence V15. V15 provides a high impedance current drive to T4, thus minimising the damping of the tuned circuit. This stage is supplied by the D rail in the transmit mode.

4.4.6 Channel oscillator

The required channel crystal is diode switched into the crystal oscillator V11 by the B rail, (SK4/1, R47, D36 for channel 1 etc). The circuit oscillates at the crystal frequency, temperature compensated and frequency adjusted by C134b, c and d, with C134a at 1/3rd capacity. Fine frequency trim is then made by C134a alone. The RF voltage is fed via C47 to the base of the common emitter amplifier V12. The amplified RF voltage is rectified by D45, filtered by C48 and fed to the base of V13 via R145 to produce a control voltage proportional to the RF amplitude. This voltage, amplified by V13 provides the DC control voltage for the base of V11 oscillator via R55 and R53, it tends to maintain the oscillator amplitude constant.

4.4.6 (cont.)

The gain of V11 is controlled by reverse AGC. However, if V11 is not oscillating (e.g. immediately after switch-on), there will be no signal derived AGC voltage and hence V11 would be bottomed by the bias voltage developed across R61. Under this condition it would have no gain and oscillations could never start. R54 and D42 ensure that bottoming cannot occur by preventing the base voltage from exceeding the collector voltage. C44 is necessary for circuit stability.

The RF voltage at the collector of V12 is also coupled via C49 to the base of V14 and a high impedance constant current drive is obtained via C50, to the balanced mixer. Frequency control via the CLARIFIER is obtained by varying the reverse bias on the Varicap diodes D43 and D44. The variable capacity thus obtained is coupled to the oscillatory circuit via C46.

Refer to para 4.2.2 for two frequency simplex switching of channel oscillators.

4.4.7 Clarifier

Five configurations are available, the components required for each are shown in the table on the circuit diagram.

The clarifier dc supply is from the B rail via a zener stabilised circuit R69 and V37. Steering diodes D47-D50 are energised to switch between a fixed voltage source (divider R67, R68) and a variable voltage source to control the Varicap diodes. Only those components needed for the clarifier option ordered will be fitted.

- (a) No clarifier : The Varicap diodes D43 and D44 are omitted and a fixed capacitor C45 (82pF) is fitted.
- (b) Narrow range clarifier, Rx only : In the receive mode, R75, R74, 1RV2 and R72 form a variable voltage divider. R74 swamps 1RV2 thus minimising variations in the limit voltage due to the tolerance of 1RV2. The variable voltage from 1RV2 wiper, varies the capacitance of D44 in parallel with C45. The D rail at ground, reverse biases D48 and grounds the voltage from the fixed divider R67 and R68 via D47.

In the transmit mode, D48 is forward biased and supplies a fixed voltage to the Varicap diode while the C rail at ground isolates the voltage from 1RV2.
- (c) Narrow range clarifier, Tx and Rx : Only one diode R49 is fitted and the variable voltage from 1RV2 is fed to Varicap diode D44, (Tx and Rx).

4.4.7 (cont.)

- (d) Wide range clarifier, Rx only : Operation is similar to that described in (b), except that R72, R74 and R75 are omitted giving wider voltage variation from 1RV2. In addition C45 is replaced by a Varicap diode D43. A wider frequency range is thus effected. R73 is fitted to assist linearity.
- (e) Wide range clarifier, Tx and Rx : Operation is similar to that described in (d), with components as in (c), i.e. only D49 is fitted to obtain clarifier operation on transmit and receive.

4.4.8 Balanced mixer

The channel oscillator output is fed to the centre tap of T4 which is connected across diode ring D32-D35. SSB signals are also fed to the diode ring via T4. The sum and difference products from the mixer are fed via wide band transformer T3, R26 and C30 to the channel gates D21-31, 82-88 (omitting alternate numbers). The required mixer product is developed across the appropriate RF tuned circuit (L11-16, 23-26) via the corresponding gate selected by the channel switch. (See Sec. 4.2.2).

4.4.9 Transmit RF amplifiers

The dc supply is derived from the D rail via R23, this fed via R24 also opens the input gate D18 (circuit completed via R25 and L10). The signal from the RF tuned circuit (L11-16, 23-26) is coupled via D18 to the base of V4 which amplifies the signal and develops it across the second RF tuned circuit (L2-7, 19-22) which is coupled into operation by D5 conducting (via R13, L9 and C rail at ground). The signal is fed via C6 to the base of V2, the first stage of a dc coupled feedback pair V2 and V1. R1 increases the output impedance of the amplifier to 50 ohms which then drives the LPF formed by C1, C2, C148, C149, L27 and T2. This filter removes any products exceeding 16 MHz which may be generated by the mixer circuitry.

4.4.10 Channel Selection

Transistors are used to convert the internal channel selection lines to "ground-to-operate". The transistor collectors drive the channel selection lines of the receiver/exciter in place of the normal channel switch. The emitters are connected to the B control rail for single frequency simplex channels, to the D rail for the transmit frequency of two-frequency simplex channels, and to the C rail for the receive frequency. Thus, if say channel 1 select line is grounded, V1 is saturated and energises the channel 1 coils and crystal on the MAIN PCB (channel selection described in para 4.2.2).

4.5 PA and Filter

4.5.1 PTT Control

Except for the output transistors V7 and V8 and resistor R42, the supply voltage to all parts of the PA assembly is controlled by the series switch V9. In the transmit mode the PTT line is at 11.5V, thus V10 conducts causing base current to flow in V9 which is driven into saturation.

4.5.2 Gain Control Amplifier & Input Stage

The leakage inductance of T1 together with C1, C2 and C3 form a low pass filter to further attenuate any unwanted high frequency signals from the exciter. The gain of IC1 is determined by the voltage at pin 7 which is generated by the ALC circuitry, such that the maximum safe PEP output is maintained for any load.

The output from pin 3 is fed via a frequency compensating network R4, R5, C7 and C8 to the bases of V3 and V4. This network together with the feedback resistor R7 determine the gain of the stage.

4.5.3 Driver Stage and Driver Bias

Transistors V5 and V6 operate in push-pull class AB.

The bias voltage is provided by V12 connected as a diode. The bias voltage (and hence the driver standing current) may be increased or decreased by fitting SOT resistor R44. The network C14 and L3 provides high frequency loading for V5 and V6.

4.5.4 Output Stage and Bias Regulator

V7 and V8 form a transformer coupled push-pull amplifier biased to operate in class AB. The dc supply to the output transistors is taken from the unregulated supply rail via a fuse. For 12V transceivers the supply is fed via T5 which provides a centre tap for the output transformer T7. For 24V transceivers the supply is fed via T5 which is the output transformer. Negative feedback from collector to base of the output transistors is provided by T4, R16 and R17.

The bias regulator is a conventional series regulator, using the base-emitter junction of V14 as the reference. This is compared against a sample of the output voltage at the emitter of V13 to generate the appropriate control signal. If more current is demanded of V13, its emitter voltage and hence the base voltage of V14 will tend to fall. Thus V14 will bleed less base current from V13, enabling it to provide the extra current demanded. V14 is thermally bonded to the heatsink and provides temperature compensation for the output transistors. Zener diode V16 prevents power supply fluctuations affecting the bias voltage. Fine adjustment of the bias voltage is provided by R51.

4.5.4 (cont.)

The dc component of the drive current (i.e. the collector current of V13) passes through the TRANSMIT lamp, hence the lamp brilliance varies with power output. Zener diode V17 protects the lamp from over-voltage when the current exceeds the lamp rating. R53 may be fitted to accommodate extremes of output transistor current gain.

4.5.5 Receive/Transmit Lamp Driver

This circuit allows a single lamp in the Control Head to indicate both power-on and transmit functions. The Control Head lamp is illuminated in the receive mode with the supply on. When the transmit mode is selected the lamp is extinguished and then flashes in sympathy with the transmitted signal. The circuit operation is as follows.

In the receive mode power is not applied to the lower level PA stages, thus the lugs L+ and L- on the remote control PCB are at or near ground potential. D17 will be reverse biased, and base current in R17 will saturate V7. Current will flow through R18 and V7 to illuminate the lamp in the Control Head.

In the transmit mode, both the lugs L+ and L- will be at the same positive potential, thus V7 is off and the lamp extinguished. When a signal is transmitted, lug L- goes negative in sympathy with the RF envelope, turning V7 on and illuminating the lamp. V7 is now a current source and does not saturate, so extra current, in addition to that provided by R17, flows through D17 and R16. Thus the total lamp current is similar to that in the receive mode.

To provide a linear voltage vs. power relationship between L+ and L- for low power levels, a resistor of 180 Ω CR25 must be fitted between the "BYPASS" pins on the PA ASSY.

4.5.6 PA Filters

A ladder type low pass filter is used. All sections are used for the lowest frequency range (2-3 MHz), and sections are switched out of circuit for higher frequency bands. Selection of the appropriate number of sections is by means of single contact relays (C to G). The coils of these relays are strapped via isolating diodes D5-10, 20-23 to the channel select lines, so that the appropriate relay is energised for the channel frequency.

4.5.7 ALC Circuits

a) Detectors

A composite ALC signal is derived from three detectors.

(i) Voltage Detector

The voltage at the collectors of V7 and V8 is sampled by T6 and rectified by D2. R9 and C21 provide frequency shaping.

(ii) Forward Power Detector

A voltage proportional to the forward power output is developed across T10 and the appropriate secondary of T9 and is rectified by D4.

(iii) Reflected Power Detector

A voltage proportional to the reflected power is developed across T8 and the appropriate secondary of T9 and is rectified by D3.

The three ALC voltages are OR-ed and used to generate the ALC voltage for the Gain Controlled Amplifier.

Under normal load conditions (50Ω) the forward power detector produces the largest output and operates the ALC. When a mismatched load is applied which increases the PA collector swing the voltage detector output increases and takes control of the ALC, maintaining a constant voltage swing at the PA collector. If the load mismatch does not increase the PA collector voltage swing, the reflected power detector will take control of the ALC when the reflected power exceeds 5W (i.e. approximately 1.6:1 VSWR) and maintains the reflected power constant with increasing VSWR.

b) ALC Processor

A reference voltage, which is proportional to the supply voltage when the supply voltage is low, and constant when the supply voltage is high, is generated by R42, R43 and V15. This voltage is fed to the inverting input of IC2b via R39, R35 and R37.

The ALC detector "peak" voltage is divided by R38 and R41 and applied to D8. The detector voltage is also fed to D7 via the "averaging" circuit R40 and C25. The "peak" and "average" voltages are OR-ed by D7 and D8 and applied to the non-inverting input of IC2b. Negative feedback is applied around IC2b by R33 to set its gain.

The output of IC2b is fed via D5 to emitter follower V2 which in turn controls the gain of IC1. Diode D5 generates a fast attack and slow decay characteristic. R39 is selected to set the power output.

4.5.8 Typical PA Voltages

Table 4.2 Typical PA Voltages
(Blue dot MRF 421)

Freq. MHz	V7/8 Coll Vpp	V5/6		V3/4 Coll Vpp	Battery Curr. Amps
		Coll Vpp	Base Vpp		
2	20	5	0.4	3	11.4
4	23	5	0.5	3.5	10.0
6	24	5	0.5	4.2	9.7
8	22	6	0.6	5	10.9
10	22	8	0.7	5.5	9.9
12	24	8.5	0.8	6	9.5
14	26	10.5	0.8	6.5	9.5
16	26	14	0.9	8	10.8

5. MAINTENANCE5.1 Fault Finding

The circuit diagrams and the relevant circuit notes give voltages at various points to enable the faulty section of the transceiver to be located.

The parameters listed below should always be checked first.

(a) Regulator Voltage	11.5V
(b) C Rail - receive	11.5V
- transmit	0V
(c) D rail - receive	0V
- transmit	11.5V
(d) AGC (no signal)	2.2V
(e) Carrier Oscillator at TP9	2.5Vpp
(f) Channel Oscillator at TP1	1.4Vpp

5.2 Transmitter precautions

When making measurements on the low level stages of the transmitter it is advisable to remove the drive to the PA stages by disconnecting SK1. Supply voltage is applied to the PA at all times when the transceiver is switched on. Due care should be exercised when connecting probes.

5.3 Probe Precautions

- (a) When connecting CRO probes to the PA assembly, wind the earth clip lead around the body of the probe such that the earth clip just reaches the probe tip. This reduces stray pick-up. Connect the earth clip to the ground plane immediately adjacent to the point of measurement to which the probe tip is connected.
- (b) It is not advisable to connect two probes simultaneously, particularly where one is earthed to the PA ground plane and one is earthed to the chassis as this may cause earth loop problems.

5.4 Lamp replacement

The POWER and TRANSMIT indicator lamps are of the long life variety, however, if necessary they can be replaced from the front panel of the transceiver.

- (a) With a pair of tweezers or small long nosed pliers, carefully unscrew anticlockwise the plastic bezel and extract the lamp bulb.
- (b) Form the leads of the replacement lamp and insert into the socket in the holder, pushing the lamp well home.
- (c) When re-fitting the bezel, ensure that the lamp does not twist as this may result in the leads shorting together. If necessary, trim the leads so that the lamp sits further into the holder.

5.5 Replacement of PA Components

To replace PA components it may be necessary to remove the PA PCB from the heatsink block. It is neither necessary nor desirable to remove the entire PA assembly, as this will avoid disturbing the thermal joint between the PA block and the rear panel heatsink.

When removing the PA PCB always remove the transistor flange fixing screws first and replace last when reassembling to minimise stressing the transistor packages. Before refitting the PCB thoroughly clean off any old thermal compound from the transistor flanges and replace with new compound (e.g. Jermyn Thermaflow A30).

5.6 Replacement of PA Output and Driver Transistors

The output and driver transistors are fitted in matched pairs to optimise amplifier performance and should only be replaced in matched pairs.

The gain grouping of the Motorola transistor type MRF421 and MRF422 are identified by a coloured dot. Only transistors of the same dot colour should be fitted.

6BA x 3/8" cheese head screws are used to secure both the driver and output transistor flanges, with the exception of the 6BA x 5/8 inch cheese head screw used to make the chassis connection for C20.

The leads of both driver and PA transistors are foiled up at the ends to facilitate removal with pliers.

5.6.1 Driver Transistors

- (a) Remove the flange fixing screws.
- (b) Using a de-soldering tool or "solder-wick" remove the bulk of the solder from each lead. Gently pull the leads away from the PCB while heating each joint. Remove the transistor.
Clear away any excess solder from the emitter, base and collector pads. Thoroughly clean the transistor mating surface on the mounting block with a cloth or tissue.
- (c) Form the leads of the replacement transistors using the discarded transistor as a guide.
- (d) Coat the transistor flange with a thin film of thermal compound (e.g. Jermyn Thermaflow A30).
- (e) Fit the transistor (check orientation) and tighten the flange fixing screws evenly.
- (f) Carefully solder the transistor leads, this should be carried out quickly using a very hot tipped soldering iron.
- (g) Readjust bias current - refer para 7.8.

5.6.2 Output Transistors

(a) Unsolder the base ends of R16 and R17, bend them clear and remove the flange fixing screws. Bend C20 clear also.

(b) to (f) Follow steps in para 5.6.1.

For para (f) - Silver loaded solder (e.g. "Capalloy" 62% tin, 36% lead and 2% silver) must be used to make the connection between the inner emitter leads and the ground plane. If silver loaded solder is not used the silver palladium terminations on chip capacitor C18 will dissolve. The chip capacitor may not be resoldered more than once or twice and small stocks of chip capacitors should be held if replacement of output transistors is undertaken.

(g) Reconnect R16 and R17 and ensure that C20 has been properly fitted.

(h) Readjust bias current - refer para 7.8.

6. CHANNEL ADDITION6.1 Introduction

This section describes the procedure to be used when adding an additional channel to a working transceiver.

6.2 Preliminary

The table below itemises all the components required to add one single frequency simplex channel. All components are mounted on the MAIN PCB.

Table 6.1

Circuit Annotation	Component Type	Qty (per Freq)
D6-17,20-31,36-41,73-92	Diode 23-10001	5
R47-52,170-173	Resistor 470 Ω 5% 1/3W	1
C37-42,122-125	Capacitor 47nF 50V Ceramic	1
L2-7,11-16,19-26	RF Coil 44-70031/ 44-70074 (ref table 6.2)	2
C8-13,24-29,C126-133	Tuning Capacitor (ref table 6.2)	2
X2-11	Crystal (ref para. 6.5)	1
C134-143 b,c,d	Compensation Capacitors (ref para 6.6)	1-3
C134a-143a	Trimmer 2-5pF (e.g. Philips type 808)	1

The transceiver has provision for up to 10 frequencies, all of which may be used for either single frequency simplex or two frequency simplex.

The channel component positions are shown on drawing number 08-01644.

6.3 RF Coil Components

For each channel fit:

- a) RF coils, type 44-70031 or 44-70074 as per Table 6.2.
- b) Four switching diodes
- c) Coil taps - from junction of switching diodes to either of pin 3 (long) or pin 4 (short) of RF coils as per table 6.2.
- d) Tuning capacitor as per table 6.2. Use either polystyrene capacitors, 5%, 63V or greater, or Ceramic N150.

Table 6.2.

Frequency (MHz)	Coil Type	Tap Length (ref 6.3)		Tuning Capacitor
		L2-7,17-20	L11-16,21-24	
1.92 - 2.1	44-70031	Long	Long	680
2.1 - 2.4	"	"	"	560
2.3 - 2.6	"	"	"	470
2.6 - 2.75	"	"	"	390
2.75 - 3.05	"	"	"	330
3.05 - 3.35	"	"	"	270
3.35 - 3.75	"	"	Short	220
3.75 - 4.1	"	"	"	180
4.1 - 4.5	"	"	"	150
4.5 - 4.85	"	"	"	120
4.85 - 5.4	"	Short	"	100
5.4 - 5.8	"	"	"	82
5.8 - 6.45	"	"	"	68
6.45 - 7.1	"	"	"	56
7.1 - 7.7	"	"	"	47
7.7 - 8.5	"	"	"	39
8.5 - 9.5	"	"	"	33
9.5 - 10.0	"	"	"	27
10.0 - 10.5	"	"	"	22
10.5 - 11.0	"	"	"	18
11.0 - 12.0	44-70074	"	"	120
12.0 - 13.0	"	"	"	100
13.0 - 14.4	"	"	"	82
14.4 - 15.6	"	"	"	68
15.6 - 16.0	"	"	"	56

6.4 Channel Oscillator

For each channel fit:

- a) Switching diode
- b) Capacitor 47n
- c) Resistor 470 Ω
- d) Trimmer capacitor, 2.2-5 pF
- e) Channel Crystal as per para 6.5
- f) Compensation Capacitors as per para 6.6

6.5 Channel Crystals

The Channel crystal frequency will normally be the intermediate frequency (1650 kHz) higher than the suppressed carrier frequency (SCF) and crystals will be marked with identification letters as follows:-

- (i) CA : CODAN Specification 01-00031 for transceivers to meet Aust. Dept. of Communications specifications over the temperature range 0...60°C with reference to the frequency at 26°C \pm 2°C.
- (ii) CB : CODAN specification 01-00049 for transceivers to meet New Zealand Post Office specifications over the temperature range -10...50°C with reference to the frequency at 20°C \pm 2°C.
- (iii) CC : CODAN specification 01-00044 for transceivers for use in tropical areas (not to Dept. of Communications or NZPO specifications) over the temperature range 20...50°C with reference to the frequency at 26°C \pm 2°C.

Fit the channel crystals to the MAIN PCB in the required order.

6.6 Compensating Capacitors

Fit compensating capacitors selected as described below.

(a) Channel crystals below 8 MHz

All crystals supplied should be within ± 40 Hz over the appropriate temperature range. Fit two 18pF P100 capacitors (e.g. Philips type 632). A 2.7pF (P100 or NPO) capacitor may be added on test in order to have the trimmer at approximately one-third capacity.

Channel crystals above 8 MHz

All crystals stamped CC, are adjusted as per para (a).

All crystals stamped CA or CB are supplied with a band-run frequency versus temperature curve chart and should be within the following limits relative to the nominal mid-temperature frequency,

<u>CA ref 26°C</u>	<u>CB ref 20°C</u>	<u>Limits</u>
0...26°C	-10...20°C	+ (10F - 40) Hz to -40 Hz
26...60°C	20...50°C	+ 40 Hz to -(10F - 40) Hz

where F is the frequency in MHz.

- (i) If the band-run indicates that the crystal is within ± 40 Hz over the temperature range fit the zero ppm correction capacitors shown in the table below.
- (ii) If the band run indicates a correction is required, determine the correction in ppm (parts per million) between minimum and maximum temperature and add capacitors selected from the following table.

<u>Correction (ppm)</u>	<u>Fixed capacitor & type</u>		<u>Additional C type</u>
0	18pF + 18pF	P100	P100
+ 2.7	12pF	N750	NPO
+ 5.1	27pF	N750	NPO
+ 7	39pF	N750	-
+ 8.2	22pF	N1500	N150
+10.4	22pF	N1500	N750
+13.2	39pF	N1500	-

6.6 (cont.)

In all cases the trimmer capacitor must be at approximately 1/3rd capacity.

In some cases where 39pF is indicated this may have to be reduced due to the stray capacity of additional channels. With the 39pF N1500 capacitor a series capacitor may be used to effect the reduction if other N1500 capacitors are not available.

Example: The maximum error of a 10 MHz crystal over the specified temperature range,
(deviation of max. temp - deviation at min. temp),
 $-(10F-40) - (10F-40) = -120 \text{ Hz}, \frac{-120}{10} = -12\text{ppm}$

∴ from the table fit the +10.4ppm

(iii) When all channel oscillators have been fitted, re-check the frequencies, the later channels fitted may have disturbed the earlier fitted channel frequencies.

6.7 P.A. Filters

The five filters are used for different frequency ranges which are marked next to the channel activate pins. To connect a filter for a particular channel, link the channel pin to the appropriate filter range pin with 25 S.W.G. tinned copper wire.

6.8 Two-Frequency Simplex

For two frequency simplex, the transmit frequency should occupy its respective channel position, and the receive frequency should occupy an unused channel position.

On the underside of the Remote Control PCB, use an appropriate sharp tool to cut the PCB track running between the B supply track and the transistor emitters for both the transmit and receive positions of the two frequency simplex channel. For the transmit position, use a link to connect the transistor emitter to the D supply track and for the receive position, link the emitter to the C supply track.

Link the channel select pins (PL1 & PL2 from the underside of the board) corresponding to the transmit and receive positions of the channel. Finally, link the filter programming lug of the transmit position to the appropriate filter for the transmit frequency.

6.9 Test Equipment Required

- (a) A calibrated CRO with 10X probe giving $10M\Omega$ and less than 12pF input impedance. Y amplifier frequency response of at least the highest channel frequency.
- (b) RF dummy load, 50Ω , 100W rms minimum.
- (c) RF signal generator covering the range 1-16 MHz and capable of providing calibrated signals down to $0.5\mu V$ emf from a 50Ω source.
- (d) Frequency counter capable of resolving to ± 1 Hz frequencies up to 16 MHz.
- (e) Regulated Power Supply which can be set to $13.6V \pm 0.2V$ or $27.2V \pm 0.4V$ (for 12V and 24V transceivers respectively) and capable of supplying 20A and 10A peak current respectively.
- (f) Two-tone (i.e. 1000 Hz and 1600 Hz) audio generator capable of providing 0-100mV rms.
- (g) Transceiver test unit to CODAN drawing 04-00316. (The isolating transformer should be screened to prevent pick-up from nearby mains transformers.)

6.10 Adjustments - General

- (a) The power supply must be set to the correct working voltage (as given in 6.10 (e)). Use the correct DC power cable. Note that the 24V transceivers have their supply polarity reversed to that for the 12V transceivers. This is so that a 12V transceiver plugged into an installation intended for a 24V transceiver will not be damaged as the reverse polarity protection circuit prevents the transceiver being turned on.

For 12V transceivers Codan type 7113 (fixed voltage) power supply may be used.

- (b) Unless otherwise stated for a particular test the mode switch is set to SSB.
- (c) The microphone or transceiver control box must be plugged in to complete the loudspeaker circuit.

CAUTION :

Inadvertant operation of the PTT switch when connected to a signal generator will seriously damage that instrument. So take due care when conducting receiver tests or alternatively disconnect the microphone or transceiver control box and short circuit the slate speaker wire to chassis to complete the loudspeaker circuit.

- (d) Replace all PCB fixing screws, and check the insulation resistance between the negative rail and the frame, it should be approximately $1M\Omega$ (R85).

6.11 Adjustments - Transmitter

- (a) Disconnect SK1 from the MAIN PCB. Connect a 50Ω resistor across PL1/1 and PL1/2.
- (b) Connect the two-tone generator to the transceiver control box and plug the latter into the microphone socket.
- (c) Switch the transceiver on and operate the PTT switch.
- (d) Observe the RF level at TP4 on the CRO and increase the output from the two-tone generator until the RF level stops increasing (compression threshold), and then increase the level by a further 10dB to 20dB.
- (e) Transfer the CRO probe to monitor the RF level across the 50Ω resistor referred to in (a).

Adjust the cores of the RF coils for maximum RF output. Repeat for each channel. If two frequency simplex channels have been fitted see (h) below.

- (f) Switch-off the two tone audio drive and connect the frequency counter to the RF output (PL1/1 and PL1/2 either side ground). The 50Ω resistor may be removed for the following test to provide a higher output to drive the counter.
- (g) Select the AM mode and adjust the crystal trimmer for the correct channel frequency at the appropriate ambient temperature (see para 6.5). Repeat for all channels, including those already fitted.

If the correct frequency cannot be obtained or the trimmer is at greater than one third capacity, then adjust the value of the compensating capacitors as described in para 6.6.

- (h) Two-frequency simplex channels (and receive only channels if fitted)

If the transceiver has two-frequency simplex channels, then channel selection should not be done with the channel switch, as it is necessary to be able to transmit on each frequency (including the receive frequencies of two-frequency channels) so as to tune the RF coils and to set the channel frequency.

Remove socket SK4. Construct a flying-lead with suitable connectors, one end of which should be plugged into PL7/5 or PL14/1 (i.e. B rail). Channel selection is then achieved by plugging the other end of the flying lead into PL4/1 for channel 1, PL4/2 for channel 2 and so on up to channel 10.

On completion of tests (a) to (g), replace socket SK4 and check with each position of the channel switch that the correct frequency is transmitted.

6.11 (cont.)

- (i) Switch the supply to the transceiver off. Select the SSB mode and connect the 50 Ω load and the CRO to the antenna socket. Set the CRO Y sensitivity to display 200Vpp. Replace SK1 on the MAIN PCB, and reconnect the two-tone drive, at minimum level.
- (j) Turn the power on and switch to transmit. The current consumption should be approximately 1 Amp. Slowly increase the two-tone audio drive from zero to maximum and check the output waveform at all levels of drive for spurious oscillation. Repeat for all additional channels.
- (k) At full drive check that the power output is within the following limits:-

100W PEP (200Vpp across 50 Ω) \pm 1dB

Compare the power supply current with that shown on the circuit diagram. Repeat for all additional channels.

NOTE 1:- If a power meter is used in lieu of a dummy load a wide range of readings can be expected from various types when fed with a two-tone SSB signal.

NOTE 2:- Many CRO's are unable to swing a full screen diameter at the highest operating frequency of the transceiver. This can be checked by observing if "flat-topping" of the two-tone envelope changes with attenuator setting.

- (l) Short circuit and open circuit the load. In general the supply current will fall to approximately 2 to 3 Amps, however on some frequencies it may be as high as 8 Amps for 12V transceivers and 5 Amps for 24V transceivers. Repeat this test on several channels over the frequency range.

6.12 Adjustments - Receiver

All adjustments required for the receiver have been carried out during adjustments of the transmitter. It is merely necessary to conduct functional tests on the receiver. Proceed as follows.

Switch to receive and connect the RF signal generator to the antenna socket (see caution in para 6.10 (c)). Set the generator level to produce 2 μ V emf and adjust the generator frequency to give an audible signal (nominally 1 kHz) in the loudspeaker.

Use the CRO to check that the signal at TP8 on the MAIN PCB is not less than 100mVpp (audio with superimposed RF). Repeat this test on all additional channels.

7. PRE-SET ADJUSTMENTS

This section describes the factory adjustment procedure. When any component which affects a pre-set adjustment is replaced the appropriate adjustment procedure should be followed. Initial installation of channel components is described in Section 6.

7.1 Test Equipment Required

- (a) A calibrated CRO with 10X probe giving $10M\Omega$ and less than 12pF input impedance. Y amplifier frequency response of at least the highest channel frequency.
- (b) RF dummy load, 50Ω , 100W rms minimum.
- (c) RF signal generator covering the range 1-16 MHz and capable of providing calibrated signals down to $0.5\mu V$ emf from a 50Ω source.
- (d) Frequency counter capable of resolving to ± 1 Hz frequencies up to 16 MHz.
- (e) Regulated Power Supply which can be set to $13.6V \pm 0.2V$ or $27.2V \pm 0.4V$ (for 12V and 24V transceivers respectively) and capable of supplying 20A or 10A peak current respectively.
- (f) Two-tone (i.e. 1000 Hz and 1600 Hz) audio generator capable of providing 0 - 100mV rms.
- (g) Multimeter or meters for measuring voltages ($20k\Omega/V$ or better) and current, 100mA and 1A ranges.
- (h) Spectrum Analyser suitable for SSB or EILCO type 6918A test set.
- (i) Transceiver test unit to Codan drawing 04-00316. (The isolating transformer should be screened to prevent pick-up from nearby mains transformers.)
- (j) Decade resistance box for ease of determining select-on-test (SOT) resistors (a resistance box constructed using the E12 values of resistors is very useful).

7.2 Preliminary

Before making any adjustments the supply voltage must be set to 13.6V $\pm 0.2V$ for 12V transceivers and 27.2V $\pm 0.4V$ for 24V transceivers.

When working on the low level stages, e.g. the receiver and exciter, the PA may be isolated by removing socket SK1 from the MAIN PCB. This will prevent unnecessary heating of the heatsink and removes the possibility of high level RF fields being picked up by test leads which could give erroneous measurements or transmitter instability.

7.3 Voltage Regulator

- (a) With the transceiver in receive, and the volume control at minimum check that the current consumption is approximately 300 mA.
- (b) For 24V transceivers check that the output from the regulator 1IC1 (mounted on the chassis near the power plug) is approximately 13.8V (no adjustment possible).
- (c) Select a value for 2R30b such that the regulated voltage measured at PL14/1 (or collector TIP32) is 11.5V $\pm 0.1V$.

NOTE: The 0V (ground) rail has three test points distributed on the MAIN PCB. Use the nearest test point for the test equipment ground connection.

7.4 Carrier Oscillator

In the receive SSB mode, connect the Frequency Counter to 2TP9 via a 10K ohm isolating resistor, (2TP6 is ground). Adjust trimmer 2C77 so that the frequency is 1650.000 kHz ± 2 Hz and this should be approximately 1/3rd in mesh. To achieve this it may be necessary to fit a small capacitor 2C79b in parallel with 2C79a (18pF). Values from 2.2pF to 3.9pF Philips 632, P100, NPO, or N150 are suitable. Where 18pF + 3.9pF is not sufficient, change 2C79a to 22pF P100.

Connect the CRO to 2TP10 and check that the oscillator amplitude lies between 3.5V and 5.5V pp. To increase the oscillator amplitude, reduce 2R121 to 10K ohm. To reduce the oscillator amplitude, increase 2R121 to 15K ohm.

7.5 Channel Oscillators

Connect the Frequency Counter to 2TP1 (2TP3 is ground). Adjust the crystal frequency to that stamped on the crystal can (i.e. 1650 kHz above the channel SCF) as follows.

Single Frequency Simplex

- (a) No clarifier. Adjust the channel crystal trimmer (C134a) to the correct frequency.
- (b) Clarifier on transmit and receive. Set the clarifier control to the mechanical centre of its range, select the highest frequency channel fitted and adjust the oscillator trimmer to the correct frequency. Measure the frequency at each end of the clarifier control. If the frequency deviation in a positive direction is less than 80% of that in a negative direction, select a value for 1R5 and fit to the clarifier control as shown on the circuit diagram to equalise the clarifier range. Re-adjust the trimmer for the correct frequency with the clarifier control at mechanical centre.
- (c) Clarifier on receive only. Adjust the crystal trimmer for the correct frequency on transmit and follow (b) for receive.

If the positive frequency deviation is greater than the negative, fit 1R5 to the opposite side of 1RV2.

Two frequency simplex

- (a) No clarifier. Adjust the appropriate crystal oscillator trimmers in the transmit and receive modes.
- (b) Clarifier on receive only. Adjust the transmit crystal trimmer in transmit and adjust the receive trimmer as in (b) of previous section.

NOTE : Clarifier options CBN or CBW are not admissable with two frequency simplex.

7.6 RF Alignment

Remove SK1 and connect a 50 resistor across the MAIN PCB output (SK1/1 & 2) and monitor the signal across the resistor with the CRO. Switch to AM and operate the PTT switch. Adjust 2T4 and the RF coils of each channel for maximum output, L2 & L11 for channel 1, L3 and L12 for channel 2 etc. The exciter output should be approximately 200mV pp dependant upon frequency (400mV pp for SSB two tone).

7.7 IF Alignment

Connect the Signal Generator to the MAIN PCB at SK1/3 & 4. Adjust to a channel frequency and of sufficient level to produce a 1 kHz tone in the loudspeaker. Connect the CRO to 2TP8 (the loudspeaker may be muted-switch to TERMINATE) and adjust 2T5 and 2T6 for maximum output. Reduce the RF signal input below AGC threshold and repeat until the best sensitivity is obtained.

7.8 PA Bias

Ensure SK1 is disconnected from the MAIN PCB.

- (a) PA Bias
Remove the PA FUSE link and insert a dc ammeter set to the 1A range. In the SSB mode, operate the PTT switch and observe the ammeter reading. Select a value for the "PA BIAS" resistor such that the standing current is between 170 and 200mA.
- (b) Driver Bias
With the drive stage LINK in position, apply full two-tone drive to the P.A. and adjust the output power to approx. 100W PEP with a "SET POWER" resistor. Observe the output on a distortion meter and select a value for the "DRIVER BIAS" resistor which gives the best 3rd order IMD products when warm. Remove the LINK and check that the driver standing current is between 50 and 75mA. Remove the "SET POWER" resistor.

7.9 ALC

Replace SK1 and ensure that the RF dummy load is connected to the antenna socket. Connect the CRO and the distortion meter (6918A) RF input (through 47k ohms) across the dummy load. Connect the audio output of the distortion meter to the test unit (AF in). Select the lowest frequency channel on the transceiver. Switch to SSB and operate the PTT switch. Adjust the value of "SET POWER" resistor to set the two-tone SSB output to 100W PEP (i.e. 200V pp). Check the IMD (Intermodulation distortion) on all channels. The power output may be decreased if necessary to give -27dB IMD on the worst channel.

N.B. -27dB IMD on the 6918A is relative to either tone and is equivalent to -33dB IMD with respect to PEP.

7.10 Receiver Performance Checks

- (a) Sensitivity and Signal + Noise to Noise ratio :

Connect an AC voltmeter across the audio output. Set the signal generator to 1 μ V emf output and adjust the frequency to produce a 1 kHz audio output.

Check that the output is at least 1V rms with the volume control fully clockwise.

Adjust the signal generator to a frequency outside the receiver passband and check that the audio output drops by at least 10dB.

- (b) AGC Check

Reset the signal generator output to 100mV emf and adjust the frequency to produce a 1 kHz audio output. Reduce the volume to a convenient level. Reduce the signal generator output until the receiver output drops by 6dB. The signal generator level should be less than 3 μ V emf.

7.10 (cont.)

(c) Audio Output

Increase the signal generator output to $100\mu\text{V}$ emf, the frequency adjusted to 1 kHz audio output. The audio output should exceed 6V rms at the onset of clipping.

(d) Selectivity (USB operation)

Centralise the Clarifier control, switch to SSB, set the signal generator output to $1\mu\text{V}$ emf and note the audio output reference level. Increase the signal generator output 60dB and using the Frequency Counter on the signal generator adjust the frequency to -1 kHz and then to +5 kHz from SCF. At these points the audio output should be less than reference level.

(e) Image rejection

With the signal generator set to produce 1 kHz audio output and $1\mu\text{V}$ emf output, note the audio output reference level. Re-adjust the signal generator frequency to the image frequency (i.e. SCF + 3301 kHz). Increase signal generator output until the reference level is again obtained. Increase should need to be greater than 45dB.

(f) Clarifier operation

Check in accordance with para 7.5.

(g) Noise Limiter operation (when fitted)

Connect a BNC T-piece into the 50Ω coax from the signal generator to the transceiver. To the unoccupied socket add a BNC to two-terminal adaptor. Connect the output from a square wave generator at a level of 5V pp at 100 Hz via a 100pF capacitor to the adaptor.

With the signal generator output set to produce a 1 kHz audio output at a $1\mu\text{V}$ emf level switch ON and OFF the NOISE LIMITER switch. When ON, the audio tone should be clearly heard if the noise limiter is effective.

7.11 Transmitter performance checks(a) Frequency

Connect the Frequency Meter via a 10K ohm resistor across the RF dummy load, switch to AM or Tune, transmit (no audio input) and measure the channel frequency (Clarifier at zero). Repeat for all channels.

(b) Clarifier (if fitted)

Check in accordance with para 7.5.

7.11 (cont.)

(c) ALC

Connect the two-tone audio output from the 6918A to the AF input of the test unit. Switch to SSB transmit, slowly increase the audio input until just beyond the point of compression. Note the PEP output and increase the audio input by 30dB. The increase in output should be less than 1dB.

(d) Power output and Intermodulation distortion

The power output on all channels should be 100W PEP \pm 1dB (i.e. 80 to 120W PEP) and the IMD should be better than -27dB as measured on the 6918A.

7.12 Mute adjustment (when fitted)

- (a) Connect an audio generator set to 800 Hz to the output of the demodulator via a 100K ohm resistor (2TP8).
- (b) Connect an ac voltmeter (preferably rms or average sensing and well damped) across the loudspeaker terminals.
- (c) Switch the receiver on and select SSB. Terminate the antenna socket with 50 Ω .
- (d) With the audio generator set to zero level and the MUTE switch OFF, adjust the VOLUME control to obtain a noise reference level on the ac voltmeter. Increase the audio generator output until the reading on the voltmeter increases by 3dB, i.e. output S+N/N = 3dB.
- (e) Turn the MUTE switch ON, set the front panel adjustment to mechanical centre and adjust the SENSITIVITY control on the mute assembly until the mute gate hunts.

If the transceiver has a mute adjustment provided on the front panel no more adjustments are required. Any adjustments to sensitivity which may be required during use can be effected with the front panel control.

NOTE: The adjustment procedure sets the system sensitivity to 0dB S/N. The sensitivity may be increased or decreased up to 3dB, by noting the audio generator level required in (d) and (g) and increasing this level by 3dB for a REDUCTION in sensitivity and vice versa.

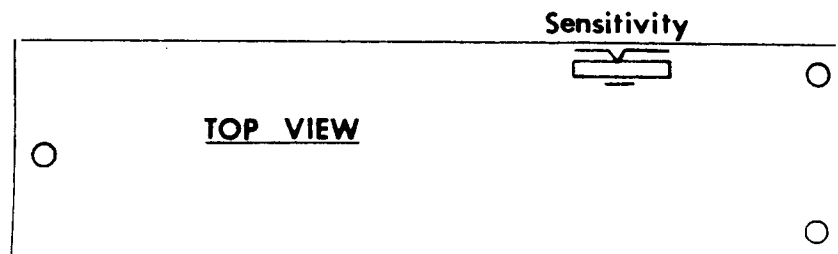

7.13 Emergency Call Assembly Adjustments (when fitted)

Connect the Frequency Counter to pin 6 of 6IC1 and operate the Emergency Call button. Resistor 6R4b is selected to set the frequency to 880 Hz \pm 5 Hz. Now connect the Frequency Counter to pin 6 of 6IC2 and select 6R10b to set the frequency the 1320 Hz approximately such that the difference frequency between the oscillators is 440 Hz \pm 2 Hz.

Connect the CRO to pin 6 of 6IC1 and 6IC2 alternately with the Emergency Call button operated. Fit either 6R1b or 6R7b to reduce the output of the oscillator with the highest output such that the amplitude difference is less than 0.2dB. The frequency must be adjusted before the amplitude, as the latter may vary with frequency.

It may be necessary to wait for as long as 5 minutes after soldering the frequency determining resistors, before checking the frequency.

8. PARTS LISTS

8.1 General Information

The parts lists contain the following information:-

- (a) Circuit Reference Number. The component location (chassis or PCB function) must be stated when ordering, see ordering information below.
- (b) Description. Gives the value and type of component.
- (c) Manufacturer. States the manufacturer and component series. Where no manufacturer is stated, the number given is a CODAN part number.

- NOTES: 1. All resistor values are in Ohms and are carbon film unless otherwise stated.
2. All electrolytic capacitors are aluminium foil unless otherwise stated.

8.1.1 Ordering Information

When ordering replacement components it is necessary to quote all of the following information to minimise the risk of obtaining the wrong part and to expedite despatch.

- (i) Equipment Type (i.e. 7727-TB).
- (ii) Component circuit reference number (e.g. R82)
- (iii) Component location (e.g. MAIN PCB, 08-01644-001).
- (iv) Full Component Description (e.g. resistor, 100k, 5%, 1/3W)
- (v) Manufacturer and type (e.g. Philips CR25).

8.1.2 Component Substitution

Due to the continuous process of up-dating equipment and variations in component availability, minor component changes may be noted from those listed. Equipment performance is in no way adversely affected.

8.2 Parts List - Index

8.2.1	Final Assy.	08-01991
8.2.2	Main PCB.	08-01644-001
8.2.3	PA PCB.	08-01914
8.2.4	Remote Control PCB	08-01946
8.2.5	Mute PCB.	08-01361
8.2.6	Emergency Call PCB.	08-00889

REF	DESCRIPTION	MAN. NAME	MAN. PARTNO	PARTNO	REMARKS
B/2	Relay 12V CR160 2C/0	Dorson	LY2F	64-11302-120	
C3	47n 63V	Sawwha	TL	46-44700-210	
C4	47n 63V	Sawwha	TL	46-44700-210	
C6	100n 250V	Phillips	2222-342-45104	46-51000-500	
C7	100n 10% 250V	Phillips	2222-342-45104	46-51000-500	
C8	100n 63V	Elna	TL	46-51000-210	
C9	100n 63V	Elna	TL	46-51000-210	
C10	100n 63V	Elna	TL	46-51000-210	
D2	Diode Si		1N4004	1N4004	
D3	Diode Si		1N4004	1N4004	
F1	Fuse STD 1.5 Amp	Australux	3AG	63-00000-150	
PL10	Plug 4Pole Panel Or Chassis Mtg	Painton	P4/MFS 310032	60-00040-030	
SK10	Socket UHF Panel Mount	Acme	C32-28	60-11363-228	
	Cover Top		7727-T	05-01904	
	Bottom Edge			05-01905	
	Microphone			08-00066	
	Cable Battery			08-00987	
	Core Toroid 6mm Grey F7	Neosid	4326/R/2/F7/EC	39-04062-107	
	Socket Housing 4Way	Molex	M2695-4	60-00044-100	
	Socket With Retainer 35Way P.MT	Painton	74/10/3556/10	60-00354-031	
	Plug Cable Mount UHF	Acme	C32-23 MN PL259	60-11163-223	
	Adaptor Reducing UHF	Acme	C32-24 MN UG175/v	60-11863-224	
	Connector Crimp Loose	Molex	M2759 TL	60-90101-001	

REF	DESCRIPTION	MAN. NAME	MAN. PARTNO	PARTNO	REMARKS
C52	1n 10% 100V CE Cap	Phillips	2222-630-03102	46-31000-200	
C53	1u 20% 35V TA Cap	ITT	TAG	47-01003-510	
C54	1n 10% 100V CE Cap	Phillips	2222-630-03102	46-31000-200	
C55	1n 10% 100V CE Cap	Phillips	2222-630-03102	46-31000-200	
C56	47n 63V CE Cap	Sawwha	TL	46-44700-210	
C57	470n 10% 250V PE Cap	Elna	NL	46-54700-511	
C58	3,3n 10% 100V CE Cap	Phillips	2222-630-03332	46-33300-200	
C62	47n 63V CE Cap	Sawwha	TL	46-44700-210	
C63	1n 10% 100V CE Cap	Phillips	2222-630-03102	46-31000-200	
C64	47n 63V CE Cap	Sawwha	TL	46-44700-210	
C65	15n 10% 100V PE Cap	Elna	NL	46-41500-510	
C66	47n 63V CE Cap	Sawwha	TL	46-44700-210	
C67	47n 63V CE Cap	Sawwha	TL	46-44700-210	
C70	47n 63V CE Cap	Sawwha	TL	46-44700-210	
C71	1u 20% 35V TA Cap	ITT	TAG	47-01003-510	
C72	10u 20% 35V TA Cap	ITT	TAG	47-11003-510	
C73	3,3n 10% 100V CE Cap	Phillips	2222-630-03332	46-33300-200	
C74	3,3n 10% 100V CE Cap	Phillips	2222-630-03332	46-33300-200	
C75	15n 10% 100V PE Cap	Elna	NL	46-41500-510	
C76	4,7u 20% 35V TA Cap	ITT	TAG	47-04703-510	
C77	1,4-5,5p 250V Foil Trim Capacitor	Phillips	2222-808-11558	49-30101	
C78	470p 5% 250V PS Cap	Phillips	2222-426-24701	46-24700-320	
C80	1n 10% 100V CE Cap	Phillips	2222-630-03102	46-31000-200	
C81	10p 2% 100V N150 CE Cap	Phillips	2222-632-34109	46-11000-012	
C83	47n 63V CE Cap	Sawwha	TL	46-44700-210	
C84	47n 63V CE Cap	Sawwha	TL	46-44700-210	
C85	1n 10% 100V CE Cap	Phillips	2222-630-03102	46-31000-200	
C86	47n 10% 100V PE Cap	Elna	NL	46-44700-510	
C87	4,7u 20% 35V TA Cap	ITT	TAG	47-04703-510	
C88	10p 2% 100V N150 CE Cap	Phillips	2222-632-34109	46-11000-012	
C90	10u 20% 35V TA Cap	ITT	TAG	47-11003-510	
C91	1u 20% 35V TA Cap	ITT	TAG	47-01003-510	
C92	470p 10% 100V CE Cap	Phillips	2222-630-03471	46-24700-200	
C93	15n 10% 100V PE Cap	Elna	NL	46-41500-510	
C94	1u 20% 35V TA Cap	ITT	TAG	47-01003-510	
C95	22u 20% 16V TA Cap	ITT	TAG	47-12201-610	
C96	100n 63V CE Cap	Elna	TL	46-51000-210	
C97	15n 10% 100V PE Cap	Elna	NL	46-41500-510	
C98	1000u 16V EL Cap	Elna	RR	48-31001-651	

REF	DESCRIPTION	MAN. NAME	MAN. PARTNO	PARTNO	REMARKS
C1	270p 2% 100V N750	CE Cap	Philips	2222-632-58271	46-22700-013
C2	330p 2% 100V N750	CE Cap	Philips	2222-632-58331	46-23300-013
C3	47n 63V	CE Cap	Samwha	TL	46-44700-210
C4	47n 63V	CE Cap	Samwha	TL	46-44700-210
C5	47n 63V	CE Cap	Samwha	TL	46-44700-210
C6	3,3n 10% 100V	CE Cap	Philips	2222-630-03332	46-33300-200
C14	47p 2% 100V N150	CE Cap	Philips	2222-632-34479	46-14700-012
C15	3,3n 10% 100V	CE Cap	Philips	2222-630-03332	46-33300-200
C16	47n 63V	CE Cap	Samwha	TL	46-44700-210
C17	3,3n 10% 100V	CE Cap	Philips	2222-630-03332	46-33300-200
C18	3,3n 10% 100V	CE Cap	Philips	2222-630-03332	46-33300-200
C19	47n 63V	CE Cap	Samwha	TL	46-44700-210
C20	47n 63V	CE Cap	Samwha	TL	46-44700-210
C21	47n 63V	CE Cap	Samwha	TL	46-44700-210
C22	3,3n 10% 100V	CE Cap	Philips	2222-630-03332	46-33300-200
C23	47n 63V	CE Cap	Samwha	TL	46-44700-210
C30	3,3n 10% 100V	CE Cap	Philips	2222-630-03332	46-33300-200
C31	47n 63V	CE Cap	Samwha	TL	46-44700-210
C32	220u 16V	EL Cap	Elna	Type RB	48-22201-651
C33	1n 10% 100V	CE Cap	Philips	2222-630-03102	46-31000-200
C34	47n 63V	CE Cap	Samwha	TL	46-44700-210
C35	39p 2% 100V N150	CE Cap	Philips	2222-632-34399	46-13900-012
C36	47n 63V	CE Cap	Samwha	TL	46-44700-210
C37	47n 63V	CE Cap	Samwha	TL	46-44700-210
C38	47n 63V	CE Cap	Samwha	TL	46-44700-210
C39	47n 63V	CE Cap	Samwha	TL	46-44700-210
C40	47n 63V	CE Cap	Samwha	TL	46-44700-210
C41	47n 63V	CE Cap	Samwha	TL	46-44700-210
C42	47n 63V	CE Cap	Samwha	TL	46-44700-210
C43	470p 5% 250V	PS Cap	Philips	2222-426-24701	46-24700-320
C44	1u 20% 35V	TA Cap	ITT	TAG	47-01003-510
C45	82p 2% 100V NPD	CE Cap	Philips	2222-632-10829	46-18200-011
C46	3,3n 10% 100V	CE Cap	Philips	2222-630-03332	46-33300-200
C47	1n 10% 100V	CE Cap	Philips	2222-630-03102	46-31000-200
C48	1n 10% 100V	CE Cap	Philips	2222-630-03102	46-31000-200
C49	3,3n 10% 100V	CE Cap	Philips	2222-630-03332	46-33300-200
C50	3,3n 10% 100V	CE Cap	Philips	2222-630-03332	46-33300-200
C51	47n 63V	CE Cap	Samwha	TL	46-44700-210

REF	DESCRIPTION	MAN. NAME	MAN. PARTNO	PARTNO	REMARKS
D32	Diode SI fast low cap high cond			23-10001	
D33	Diode SI fast low cap high cond			23-10001	
D34	Diode SI fast low cap high cond			23-10001	
D35	Diode SI fast low cap high cond			23-10001	
D36	Diode SI fast low cap high cond			23-10001	
D42	Diode SI fast low cap high cond			23-10001	
D45	Diode SI fast low cap med cond			23-10002	
D47	Diode SI fast low cap med cond			23-10002	
D56	Diode SI fast low cap med cond			23-10002	
D57	Diode SI fast low cap med cond			23-10002	
D58	Diode SI fast low cap med cond			23-10002	
D59	Diode SI fast low cap high cond			23-10001	
D60	Diode SI fast low cap high cond			23-10001	
D61	Diode SI fast low cap high cond			23-10001	
D62	Diode SI fast low cap high cond			23-10001	
D65	Diode SI fast low cap med cond			23-10002	
FL1	Filter		QF0 1602		65-91101-000
IC1	Operational Amplifier	IC National	LM748CN		XA-00748-000
IC2	Audio Amplifier	IC Fairchild	TR4810AS		TR4810AS
L2	Coil RF Orange Dot				44-70031
L8	Choke 1mH	Sigma	SC10/49		43-83100-051
L9	Choke 1mH	Sigma	SC10/49		43-83100-051
L10	Choke 1mH	Sigma	SC10/49		43-83100-051
L11	Coil RF Orange Dot				44-70031
L17	Choke 1mH	Sigma	SC10/49		43-83100-051
L27	Inductor .380H				44-70232
PL1	Plug 4Way Standard Wafer	Molex	M4030-4/14, 22MM		60-00041-100
PL2	Plug 4Way Standard Wafer	Molex	M4030-4/14, 22MM		60-00041-100
PL4	Plug 10Way Standard Wafer	Molex	M4030-10/14, 22MM		60-00101-100
PL5	Plug 10Way Standard Wafer	Molex	M4030-10/14, 22MM		60-00101-100
PL6	Plug 4Way Standard Wafer	Molex	M4030-4/14, 22MM		60-00041-100

REF	DESCRIPTION	MAN. NAME	MAN. PARTNO	PARTNO	REMARKS
C99	3,3n 10%	CE Cap	Philips	2222-630-03332	46-33300-200
C101	100n 63V	CE Cap	Elna	TL	46-51000-210
C102	1000u	EL Cap	Elna	RB	48-31001-651
C103	1u 20%	TA Cap	ITT	TAG	47-01003-510
C104	1n 10%	CE Cap	Philips	2222-630-03102	46-31000-200
C107	100P 2%	CE Cap	Philips	2222-632-34101	46-21000-012
C108	100P 2%	CE Cap	Philips	2222-632-34101	46-21000-012
C109	47n 63V	CE Cap	Sawwha	TL	46-44700-210
C111	22u 20%	TA Cap	ITT	TAG	47-12201-610
C112	22u 20%	TA Cap	ITT	TAG	47-12201-610
C113	3,3n 10%	CE Cap	Philips	2222-630-03332	46-33300-200
C122	47n 63V	CE Cap	Sawwha	TL	46-44700-210
C123	47n 63V	CE Cap	Sawwha	TL	46-44700-210
C124	47n 63V	CE Cap	Sawwha	TL	46-44700-210
C125	47n 63V	CE Cap	Sawwha	TL	46-44700-210
C134	18P 2%	100V P100 CE Cap	Philips	2222-632-04189	46-11800-010
C134	1,4-5,5P 250V	Foil Trim Capacito	Philips	2222-808-11558	46-11800-010
C135	18P 2%	100V P100 CE Cap	Philips	2222-632-04189	49-30101
C144	100n 63V	CE Cap	Elna	TL	46-11800-010
C145	3,3P 0,25P	100V NPO CE Cap	Philips	2222-632-09338	46-51000-210
C146	180P 2%	100V N750 CE Cap	Philips	2222-632-58181	46-03300-011
C147	39P 2%	100V N750 CE Cap	Philips	2222-632-58399	46-21800-013
C148	150P 2%	100V N750 CE Cap	Philips	2222-632-58151	46-13900-013
C149	180P 2%	100V N750 CE Cap	Philips	2222-632-58181	46-21500-013
C150	15P 2%	100V N150 CE Cap	Philips	2222-632-34159	46-21800-013
C79d	18P 2%	100V P100 CE Cap	Philips	2222-632-04189	46-11500-012
					46-11800-010
D1	Diode SI fast	low cap med cond		23-10002	
D2	Diode SI fast	low cap high cond		23-10001	
D3	Diode SI fast	low cap med cond	1N4004	23-10002	
D4	Diode SI		1N4004	1N4004	
D5	Diode SI fast	low cap high cond		23-10001	
D6	Diode SI fast	low cap high cond		23-10001	
D8	Diode SI fast	low cap high cond		23-10001	
D18	Diode SI fast	low cap med cond		23-10002	
D19	Diode SI fast	low cap med cond		23-10002	
D20	Diode SI fast	low cap med cond		23-10002	
D21	Diode SI fast	low cap med cond		23-10002	

REF	DESCRIPTION	MAN. NAME	MAN. PARTNO	PARTNO	REMARKS
R39	2,2k Ohm 5% 0,33W CF Res	Phillips	CR25	40-32200-020	
R40	68 Ohm 5% 0,33W CF Res	Phillips	CR25	40-16800-020	
R41	1,5k Ohm 5% 0,33W CF Res	Phillips	CR25	40-31500-020	
R46	22 Ohm 5% 0,33W CF Res	Phillips	CR25	40-12200-020	
R47	470 Ohm 5% 0,33W CF Res	Phillips	CR25	40-24700-020	
R53	47k Ohm 5% 0,33W CF Res	Phillips	CR25	40-44700-020	
R54	1k Ohm 5% 0,33W CF Res	Phillips	CR25	40-31000-020	
R55	10k Ohm 5% 0,33W CF Res	Phillips	CR25	40-41000-020	
R56	47k Ohm 5% 0,33W CF Res	Phillips	CR25	40-44700-020	
R57	4,7k Ohm 5% 0,33W CF Res	Phillips	CR25	40-34700-020	
R58	100 Ohm 5% 0,33W CF Res	Phillips	CR25	40-21000-020	
R59	470k Ohm 5% 0,33W CF Res	Phillips	CR25	40-54700-020	
R61	22k Ohm 5% 0,33W CF Res	Phillips	CR25	40-42200-020	
R62	820 Ohm 5% 0,33W CF Res	Phillips	CR25	40-28200-020	
R63	5,6k Ohm 5% 0,33W CF Res	Phillips	CR25	40-35600-020	
R64	100 Ohm 5% 0,33W CF Res	Phillips	CR25	40-21000-020	
R65	1k Ohm 5% 0,33W CF Res	Phillips	CR25	40-31000-020	
R66	22 Ohm 5% 0,33W CF Res	Phillips	CR25	40-12200-020	
R76	270 Ohm 5% 0,33W CF Res	Phillips	CR25	40-22700-020	
R77	1k Ohm 5% 0,33W CF Res	Phillips	CR25	40-31000-020	
R78	2,7k Ohm 5% 0,33W CF Res	Phillips	CR25	40-32700-020	
R79	10k Ohm 5% 0,33W CF Res	Phillips	CR25	40-41000-020	
R80	47k Ohm 5% 0,33W CF Res	Phillips	CR25	40-44700-020	
R81	47k Ohm 5% 0,33W CF Res	Phillips	CR25	40-44700-020	
R82	100k Ohm 5% 0,33W CF Res	Phillips	CR25	40-51000-020	
R83	1,8k Ohm 5% 0,33W CF Res	Phillips	CR25	40-31800-020	
R84	100 Ohm 5% 0,33W CF Res	Phillips	CR25	40-21000-020	
R85	1M Ohm 5% 0,33W CF Res	Phillips	CR25	40-61000-020	
R88	820 Ohm 5% 0,33W CF Res	Phillips	CR25	40-28200-020	
R89	2,2k Ohm 5% 0,33W CF Res	Phillips	CR25	40-32200-020	
R90	100 Ohm 5% 0,33W CF Res	Phillips	CR25	40-21000-020	
R91	1k Ohm 5% 0,33W CF Res	Phillips	CR25	40-31000-020	
R92	390 Ohm 5% 0,33W CF Res	Phillips	CR25	40-23900-020	
R93	8,2k Ohm 5% 0,33W CF Res	Phillips	CR25	40-38200-020	
R94	1k Ohm 5% 0,33W CF Res	Phillips	CR25	40-31000-020	
R95	100 Ohm 5% 0,33W CF Res	Phillips	CR25	40-21000-020	
R96	100 Ohm 5% 0,33W CF Res	Phillips	CR25	40-21000-020	
R97	330 Ohm 5% 0,33W CF Res	Phillips	CR25	40-23300-020	
R98	820 Ohm 5% 0,33W CF Res	Phillips	CR25	40-28200-020	

RTF	DESCRIPTION	MAN. NAME	MAN. PARTNO	PARTNO	REMARKS
P17	Plug 10Way Standard Wafer	Molex	M4030-10/14,22MM	60-00101-100	
P1.14	Plug 4Way Standard Wafer	Molex	M4030-4/14,22MM	60-00041-100	
R1	47 Ohm 5% 0,33W	CF Res	Philips	CR25	40-14700-020
R2	1k Ohm 5% 0,33W	CF Res	Philips	CR25	40-31000-020
R3	470 Ohm 5% 0,33W	CF Res	Philips	CR25	40-24700-020
R4	470 Ohm 5% 0,33W	CF Res	Philips	CR25	40-24700-020
R5	560 Ohm 5% 0,33W	CF Res	Philips	CR25	40-25600-020
R6	100 Ohm 5% 0,33W	CF Res	Philips	CR25	40-21000-020
R7	150k Ohm 5% 0,33W	CF Res	Philips	CR25	40-51500-020
R8	39k Ohm 5% 0,33W	CF Res	Philips	CR25	40-43700-020
R9	180 Ohm 5% 0,33W	CF Res	Philips	CR25	40-21800-020
R10	1k Ohm 5% 0,33W	CF Res	Philips	CR25	40-31000-020
R11	2,2k Ohm 5% 0,33W	CF Res	Philips	CR25	40-32200-020
R12	220 Ohm 5% 0,33W	CF Res	Philips	CR25	40-22200-020
R13	100 Ohm 5% 0,33W	CF Res	Philips	CR25	40-21000-020
R14	1k Ohm 5% 0,33W	CF Res	Philips	CR25	40-31000-020
R15	390 Ohm 5% 0,33W	CF Res	Philips	CR25	40-23900-020
R16	3,3k Ohm 5% 0,33W	CF Res	Philips	CR25	40-33300-020
R17	1,8k Ohm 5% 0,33W	CF Res	Philips	CR25	40-31800-020
R18	150 Ohm 5% 0,33W	CF Res	Philips	CR25	40-21500-020
R19	3,3k Ohm 5% 0,33W	CF Res	Philips	CR25	40-33300-020
R20	22 Ohm 5% 0,33W	CF Res	Philips	CR25	40-12200-020
R23	22 Ohm 5% 0,33W	CF Res	Philips	CR25	40-12200-020
R24	3,3k Ohm 5% 0,33W	CF Res	Philips	CR25	40-33300-020
R25	470 Ohm 5% 0,33W	CF Res	Philips	CR25	40-24700-020
R26	1k Ohm 5% 0,33W	CF Res	Philips	CR25	40-31000-020
R27	33 Ohm 5% 0,33W	CF Res	Philips	CR25	40-13300-020
R28	22k Ohm 5% 0,33W	CF Res	Philips	CR25	40-42200-020
R29	1,5k Ohm 5% 0,33W	CF Res	Philips	CR25	40-31500-020
R31	220 Ohm 5% 0,33W	CF Res	Philips	CR25	40-22200-020
R32	1k Ohm 5% 0,33W	CF Res	Philips	CR25	40-31000-020
R33	22k Ohm 5% 0,33W	CF Res	Philips	CR25	40-42200-020
R34	15k Ohm 5% 0,33W	CF Res	Philips	CR25	40-41500-020
R35	680 Ohm 5% 0,33W	CF Res	Philips	CR25	40-26800-020
R36	2,7k Ohm 5% 0,33W	CF Res	Philips	CR25	40-32700-020
R37	100 Ohm 5% 0,33W	CF Res	Philips	CR25	40-21000-020
R38	10k Ohm 5% 0,33W	CF Res	Philips	CR25	40-41000-020

REF	DESCRIPTION	MAN. NAME	MAN. PARTNO	PARTNO	REMARKS
R141	100k Ohm 5% 0,33W	Philips	CR25	40-51000-020	
R142	47 Ohm 5% 0,33W	Philips	CR25	40-14700-020	
R143	2,7 Ohm 5% 0,33W	Philips	CR25	40-02700-020	
R144	680 Ohm 5% 0,33W	Philips	CR25	40-26800-020	
R145	22k Ohm 5% 0,33W	Philips	CR25	40-42200-020	
R146	4,7k Ohm 5% 0,33W	Philips	CR25	40-34700-020	
R147	47k Ohm 5% 0,33W	Philips	CR25	40-44700-020	
R152	10k Ohm 5% 0,33W	Philips	CR25	40-41000-020	
R154	100 Ohm 5% 0,33W	Philips	CR25	40-21000-020	
R166	1,5k Ohm 5% 0,33W	Philips	CR25	40-31500-020	
R167	2,7k Ohm 5% 0,33W	Philips	CR25	40-32700-020	
R168	18k Ohm 5% 0,33W	Philips	CR25	40-41800-020	
R169	10k Ohm 5% 0,33W	Philips	CR25	40-41000-020	
R170	100k Ohm 5% 0,33W	Philips	CR25	40-51000-020	
R30a	1k Ohm 5% 0,33W	Philips	CR25	40-31000-020	
R30b	S.O.T. 5% 0,33W	Philips	CR25	40-00000-020	

T1	Transformer RF			44-80022	
T2	Transformer RF			44-80023	
T3	Transformer RF			44-80024	
T4	Transformer RF Green Dot			44-70032	
T5	Transformer RF Green Dot			44-70032	
T6	Transformer RF Green Dot			44-70032	
T7	Transformer RF			44-80073	
T8	Transformer Audio			44-30642	
T9	Transformer RF			44-80104	

Issue 2

V1	Transistor PNP Si	Philips	PN4916	PN4916	
V2	Transistor NPN Si	Philips	BF494	BF494	
V3	Transistor NPN White Spot BF198		To Spec 10-00096		
V4	Transistor NPN Si	Philips	BF494	BF494	
V5	Transistor NPN	Philips	BC548	BC548	
V6	Transistor PNP Si c/w mtg kit	Motorola	T1F32A	T1F32A	
V7	Transistor NPN	Philips	BC548	BC548	
V8	Transistor NPN Si	Philips	BF494	BF494	
V9	Transistor PNP Si		PN4916	PN4916	

REF	DESCRIPTION	MAN. NAME	MAN. PARTNO	PARTNO	REMARKS
R102	3,3k Ohm 5%	Philips	CR25	40-33300-020	
R103	10k Ohm 5%	Philips	CR25	40-41000-020	
R104	100 Ohm 5%	Philips	CR25	40-21000-020	
R105	220k Ohm 5%	Philips	CR25	40-52200-020	
R106	1k Ohm 5%	Philips	CR25	40-31000-020	
R107	1k Ohm 5%	Philips	CR25	40-31000-020	
R108	1k Ohm 5%	Philips	CR25	40-31000-020	
R109	2,7k Ohm 5%	Philips	CR25	40-32700-020	
R110	10k Ohm 5%	Philips	CR25	40-41000-020	
R111	10k Ohm 5%	Philips	CR25	40-41000-020	
R112	220 Ohm 5%	Philips	CR25	40-22200-020	
R113	820 Ohm 5%	Philips	CR25	40-28200-020	
R114	10k Ohm 5%	Philips	CR25	40-41000-020	
R115	4,7k Ohm 5%	Philips	CR25	40-34700-020	
R116	560 Ohm 5%	Philips	CR25	40-25600-020	
R117	560 Ohm 5%	Philips	CR25	40-25600-020	
R118	47 Ohm 5%	Philips	CR25	40-14700-020	
R119	3,9k Ohm 5%	Philips	CR25	40-33900-020	
R120	47k Ohm 5%	Philips	CR25	40-44700-020	
R121	S.O.T.	Philips	CR25	40-00000-020	
R122	470 Ohm 5%	Philips	CR25	40-24700-020	
R123	1k Ohm 5%	Philips	CR25	40-31000-020	
R124	47 Ohm 5%	Philips	CR25	40-14700-020	
R125	3,3k Ohm 5%	Philips	CR25	40-33300-020	
R126	10k Ohm 5%	Philips	CR25	40-41000-020	
R127	2,2k Ohm 5%	Philips	CR25	40-32200-020	
R128	4,7k Ohm 5%	Philips	CR25	40-34700-020	
R129	4,7k Ohm 5%	Philips	CR25	40-34700-020	
R130	1k Ohm 5%	Philips	CR25	40-31000-020	
R131	33k Ohm 5%	Philips	CR25	40-43300-020	
R132	1k Ohm 5%	Philips	CR25	40-31000-020	
R133	270k Ohm 5%	Philips	CR25	40-52700-020	
R134	12k Ohm 5%	Philips	CR25	40-41200-020	
R135	100 Ohm 5%	Philips	CR25	40-21000-020	
R136	1k Ohm 5%	Philips	CR25	40-31000-020	
R137	470k Ohm 5%	Philips	CR25	40-54700-020	
R138	2,2k Ohm 5%	Philips	CR25	40-32200-020	
R139	22k Ohm 5%	Philips	CR25	40-42200-020	
R140	10k Ohm 5%	Philips	CR25	40-41000-020	

REF	DESCRIPTION	MAN. NAME	MAN. PARTNO	PARTNO	REMARKS
D43	Diode Si		NV2209	23-40001	
D44	Diode Si		MV2209	23-40001	
D48	Diode Si fast low cap med cond			23-10002	
D49	Diode Si fast low cap med cond			23-10002	
D50	Diode Si fast low cap med cond			23-10002	

R5	S.O.T.	5%	0,33W	CF Res	Phillips	CR25	40-00000-020
R60	220k Ohm	5%	0,33W	CF Res	Phillips	CR25	40-52200-020
R67	10k Ohm	5%	0,33W	CF Res	Phillips	CR25	40-41000-020
R68	6,8k Ohm	5%	0,33W	CF Res	Phillips	CR25	40-36800-020
R69	1k Ohm	5%	0,33W	CF Res	Phillips	CR25	40-31000-020
R70	470k Ohm	5%	0,33W	CF Res	Phillips	CR25	40-54700-020
R71	5,6k Ohm	5%	0,33W	CF Res	Phillips	CR25	40-35600-020
R72	6,2k Ohm	5%	0,33W	CF Res	Phillips	CR25	40-36200-020
R74	12k Ohm	5%	0,33W	CF Res	Phillips	CR25	40-41200-020
R75	8,2k Ohm	5%	0,33W	CF Res	Phillips	CR25	40-38200-020

Z2	Diode Zener Si 6,8V				Phillips	BZX79-C6V8	BZX79C6V8
----	---------------------	--	--	--	----------	------------	-----------

REF	DESCRIPTION	MAN. NAME	MAN. PARTNO	PARTNO	REMARKS
V11	Transistor NPN Si	Phillips	BF494	BF494	
V12	Transistor NPN Si	Phillips	BF494	BF494	
V13	Transistor PNP Si	Phillips	BC558	BC558	
V14	Transistor PNP Si		PN4916	PN4916	
V15	Transistor PNP Si		1-N4916	PN4916	
V16	Transistor NPN Si	Phillips	BF494	BF494	
V17	Transistor NPN Red Spot BF198		To spec 10-00096	23-20005-001	
V18	Transistor NPN Si	Phillips	BF494	BF494	
V19	Transistor NPN Si	Phillips	BF494	BF494	
V20	Transistor NPN Si	Phillips	BC558	BC558	
V21	Transistor NPN Si	Phillips	BF494	BF494	
V22	Transistor NPN Si	Phillips	BF494	BF494	
V23	Transistor NPN Si		1-N4916	PN4916	
V24	Transistor NPN Si	Phillips	BF494	BF494	
V25	Transistor NPN Si	Phillips	BC328	BC328	
V26	Transistor NPN Si	Phillips	BC548	BC548	
V27	Transistor NPN	Phillips	BC548	BC548	
V28	Transistor PNP Si	Phillips	BC558	BC558	
V29	Fet Junction P Channel Si		1H245B	RF245B	
V33	Transistor NPN	Phillips	BC548	BC548	
V36	Diode Zener Si 9,1V	Phillips	R7X79-C9V1	R7X79C9V1	
V38	Diode Zener Si 3,9V	Phillips	RZY88-C3V9	RZY88C3V9	
V39	Diode Zener Si 6,8V	Phillips	RZX79-C6V8	RZX79C6V8	

X1 Crystal 1650 KHZ C.A. 01-00031

To Spec 01-00031

65-90004-000

8.2.2 PCB Main 16MHz Option Noise Limiter ASSEMBLY 08 01644 001 PCB 07 00557 All components prefixed 2

REF	DESCRIPTION	MAN. NAME	MAN. PARTNO	PARTNO	REMARKS
T201	Transformer RF			44-80037	
T202	Transformer RF			44-80037	
V201	Transistor PNP SI	Phillips	BC558	BC558	
V202	Transistor NPN SI	Phillips	BF494	BF494	
V203	Transistor NPN White Spot		To Spec 10-00096	23-20005-002	
Z201	Diode Zener SI 5,6V	Phillips	BZX79-C5V6	BZX79C5V6	

REF	DESCRIPTION	MAN. NAME	MAN. PARTNO	PARTNO	REMARKS
C201	47n 63V CE Cap	Sawuha	TL	46-44700-210	
C202	1u 35V TA Cap	ITT	TAG	47-01003-510	
C203	1u 35V TA Cap	ITT	TAG	47-01003-510	
C204	47n 63V CE Cap	Sawuha	TL	46-44700-210	
C206	82p 100V N150 CE Cap	Phillips	2222-632-34829	46-18200-012	
C207	470p 100V CE Cap	Phillips	2222-630-03471	46-24700-200	
C208	47n 63V CE Cap	Sawuha	TL	46-44700-210	
C209	3,3n 100V CE Cap	Phillips	2222-630-03332	46-33300-200	
C210	560p 500V PS Cap	Phillips	2222-427-25601	46-25600-330	
C211	47n 63V CE Cap	Sawuha	TL	46-44700-210	
C212	47n 63V CE Cap	Sawuha	TL	46-44700-210	
C213	100p 100V N150 CE Cap	Phillips	2222-632-34101	46-21000-012	
D202	Diode SI fast low cap med cond			23-10002	
D203	Diode SI fast low cap med cond			23-10002	
D204	Diode SI fast low cap med cond			23-10002	
D205	Diode SI fast low cap med cond			23-10002	
L201	Choke 0,1mH	Sigma	SC60/25	43-82100-071	
L202	Transformer RF			44-80007	
R201	10k Ohm 5% 0,33W CF Res	Phillips	CR25	40-41000-020	
R202	2,7k Ohm 5% 0,33W CF Res	Phillips	CR25	40-32700-020	
R203	10k Ohm 5% 0,33W CF Res	Phillips	CR25	40-41000-020	
R204	33k Ohm 5% 0,33W CF Res	Phillips	CR25	40-43300-020	
R205	1k Ohm 5% 0,33W CF Res	Phillips	CR25	40-31000-020	
R206	100 Ohm 5% 0,33W CF Res	Phillips	CR25	40-21000-020	
R208	2,2k Ohm 5% 0,33W CF Res	Phillips	CR25	40-32200-020	
R210	1k Ohm 5% 0,33W CF Res	Phillips	CR25	40-31000-020	
R211	3,3k Ohm 5% 0,33W CF Res	Phillips	CR25	40-33300-020	
R212	390 Ohm 5% 0,33W CF Res	Phillips	CR25	40-23900-020	
K213	100 Ohm 5% 0,33W CF Res	Phillips	CR25	40-21000-020	
R214	820 Ohm 5% 0,33W CF Res	Phillips	CR25	40-28200-020	
R215	3,3k Ohm 5% 0,33W CF Res	Phillips	CR25	40-33300-020	

REF	DESCRIPTION	MAN. NAME	MAN. PARTNO	PARTNO	REMARKS
R151	1k Ohm 5% 0,33W	Phillips	CR25	40--31000--020	
R155	4,7k Ohm 5% 0,33W	Phillips	CR25	40--34700--020	
R156	100 Ohm 5% 0,33W	Phillips	CR25	40--21000--020	
R157	100 Ohm 5% 0,33W	Phillips	CR25	40--21000--020	
R158	6,8k Ohm 5% 0,33W	Phillips	CR25	40--36800--020	
R159	10k Ohm 5% 0,33W	Phillips	CR25	40--41000--020	
R160	10k Ohm 5% 0,33W	Phillips	CR25	40--41000--020	
R161	4,7k Ohm 5% 0,33W	Phillips	CR25	40--34700--020	
R162	4,7k Ohm 5% 0,33W	Phillips	CR25	40--34700--020	
R163	6,8k Ohm 5% 0,33W	Phillips	CR25	40--36800--020	
R164	4,7k Ohm 5% 0,33W	Phillips	CR25	40--34700--020	
R165	47 Ohm 5% 0,33W	Phillips	CR25	40--14700--020	

V32 Transistor NPN
 V34 Transistor NPN
 V35 Transistor NPN

Phillips
 Phillips
 Phillips

BC548
 BC548
 BC548

BC548
 BC548
 BC548

REF	DESCRIPTION	MAN. NAME	MAN. PARTNO	PARTNO	REMARKS
C59	3,3n 10% 100V	CE Cap	Philips	2222-630-03332	46-33300-200
C68	1u 20% 35V	TA Cap	ITT	TAG	47-01003-510
C69	1n 10% 100V	CE Cap	Philips	2222-630-03102	46-31000-200
C82	2-22p 250V Foil Trim Capacitor	Philips	2222-808-11229	49-30102	46-30102
C114	3,3n 10% 100V	CE Cap	Philips	2222-630-03332	46-33300-200
C115	3,3n 10% 100V	CE Cap	Philips	2222-630-03332	46-33300-200
C116	47n	CE Cap	Sawwha	TL	46-44700-210
C117	47n	CE Cap	Sawwha	TL	46-44700-210
C118	47n	CE Cap	Sawwha	TL	46-44700-210
C119	47n	CE Cap	Sawwha	TL	46-44700-210
C120	47n	CE Cap	Sawwha	TL	46-44700-210
C121	47n	CE Cap	Sawwha	TL	46-44700-210
D53	Diode Si fast low cap med cond			23-10002	
D54	Diode Signal Ge	Philips	0A91	0A91	
D55	Diode Si fast low cap med cond			23-10002	
D67	Diode Si fast low cap high cond			23-10001	
D68	Diode Si fast low cap high cond			23-10001	
D69	Diode Si fast low cap med cond			23-10002	
D70	Diode Si fast low cap med cond			23-10002	
D71	Diode Si fast low cap med cond			23-10002	
D72	Diode Si fast low cap med cond			23-10002	
FL2	Filter		QF01601	QF01601	65-91100-000
			QF01606	QF01606	65-91102-000
L18	Choke 1mH	Sigma	SC10/49	SC10/49	43-83100-051
R86	10k Ohm 5% 0,33W	CF Res	Philips	CR25	40-41000-020
R99	5,6k Ohm 5% 0,33W	CF Res	Philips	CR25	40-35600-020
R100	5,6k Ohm 5% 0,33W	CF Res	Philips	CR25	40-35600-020
R101	4,7k Ohm 5% 0,33W	CF Res	Philips	CR25	40-34700-020
R148	22 Ohm 5% 0,33W	CF Res	Philips	CR25	40-12200-020
R149	22 Ohm 5% 0,33W	CF Res	Philips	CR25	40-12200-020
R150	47k Ohm 5% 0,33W	CF Res	Philips	CR25	40-44700-020

REF	DESCRIPTION	MAN. NAME	MAN. PARTNO	PARTNO	REMARKS
IC1	Amplifier AGC	Plessey	SL610CT	SL610C	
IC2	Operational Amplifier Dual	National	LM358N	XA-00358-100	
L1	Inductor			44-80044	
L2	Inductor			44-80044	
L4	Inductor			44-80044	
L5	Inductor			44-80044	
R1	15 Ohm	Phillips	CR25	40-11500-020	
R2	180 Ohm	Phillips	CR25	40-21800-020	
R3	10k Ohm	Phillips	CR25	40-41000-020	
R4	680 Ohm	Phillips	CR25	40-26800-020	
R5	220 Ohm	Phillips	CR25	40-22200-020	
R6	220k Ohm	Phillips	CR25	40-52200-020	
R7	5,6k Ohm	Phillips	CR25	40-35600-020	
R8	1k Ohm	Phillips	CR25	40-31000-020	
R9	100 Ohm	Phillips	CR25	40-21000-020	
R10	10 Ohm	Phillips	CR25	40-11000-020	
R11	100 Ohm	Phillips	CR25	40-21000-020	
R12	1 Ohm	Phillips	CR25	40-01000-020	
R13	1 Ohm	Phillips	CR25	40-01000-020	
R14	1 Ohm	Phillips	CR25	40-01000-020	
R15	1 Ohm	Phillips	CR25	40-01000-020	
R16	6,8 Ohm	Phillips	CR37	40-06800-030	
R17	6,8 Ohm	Phillips	CR37	40-06800-030	
R18	4,7 Ohm	Phillips	CR25	40-04700-020	
R19	39 Ohm	Phillips	CR25	40-13900-020	
R20	220 Ohm	Phillips	CR68	40-22200-050	
R21	150 Ohm	Phillips	CR25	40-21500-020	
R22	1k Ohm	Phillips	CR25	40-31000-020	
R23	330 Ohm	Phillips	CR25	40-23300-020	
R24	330 Ohm	Phillips	CR25	40-23300-020	
R25	39 Ohm	Phillips	CR25	40-13900-020	
R26	270 Ohm	Phillips	CR25	40-22700-020	
R32	220 Ohm	Phillips	CR25	40-22200-020	
R33	68k Ohm	Phillips	CR25	40-46800-020	

REF	DESCRIPTION	MAN. NAME	MAN. PARTNO	PARTNO	REMARKS
C1	150P 2% 100V N750 CE Cap Phillips		2222-632-58151	46-21500-013	
C2	270P 2% 100V N750 CE Cap Phillips		2222-632-58271	46-22700-013	
C3	330P 2% 100V N750 CE Cap Phillips		2222-632-58331	46-23300-013	
C4	47n 63V CE Cap Samwha		TL	46-44700-210	
C5	68u 16V EL Cap Phillips		2222-030-25689	48-16801-611	
C6	4,7u 35V TA Cap ITT		TAG	47-04703-510	
C7	27P 2% 100V N750 CE Cap Phillips		2222-632-58279	46-12700-013	
C8	330P 2% 100V N750 CE Cap Phillips		2222-632-58331	46-23300-013	
C9	68u 16V EL Cap Phillips		2222-030-25689	48-16801-611	
C10	47n 63V CE Cap Samwha		TL	46-44700-210	
C11	47n 63V CE Cap Samwha		TL	46-44700-210	
C12	47n 63V CE Cap Samwha		TL	46-44700-210	
C13	100n 10% 100V CE Cap Vitramon		VJ1808Y104KF	46-51000-280	
C14	150P 2% 100V N750 CE Cap Phillips		2222-632-58151	46-21500-013	
C16	100n 10% 100V CC Cap Vitramon		VJ1808Y104KF	46-51000-280	
C17	3,3n 10% 100V CE Cap Phillips		2222-630-03332	46-33300-200	
C18	470n 20% 50V CC Cap Vitramon		VJ2321X474MF	46-54700-280	
C19	68u 16V EL Cap Phillips		2222-030-25689	48-16801-611	
C20	47n 10% 250V PE Cap Phillips		2222-342-45473	46-44700-500	
C21	180P 2% 100V N750 CE Cap Phillips		2222-632-58181	46-21800-013	
C22	3,3n 10% 100V CE Cap Phillips		2222-630-03332	46-33300-200	
C23	47n 63V CE Cap Samwha		TL	46-44700-210	
C24	1n 10% 100V CE Cap Phillips		2222-630-03102	46-31000-200	
C25	1u 20% 35V TA Cap ITT		TAG	47-01003-510	
C26	10u 20% 35V TA Cap ITT		TAG	47-11003-510	
C27	47n 63V CE Cap Samwha		TL	46-44700-210	
C28	10u 20% 35V TA Cap ITT		TAG	47-11003-510	
C29	10u 20% 35V TA Cap ITT		TAG	47-11003-510	
D1	Diode SI fast low cap med cond			23-10002	
D2	Diode SI fast low cap med cond			23-10002	
D3	Diode SI fast low cap med cond			23-10002	
D4	Diode SI fast low cap med cond			23-10002	
D5	Diode SI fast low cap med cond			23-10002	
D7	Diode SI fast low cap med cond			23-10002	
D8	Diode SI fast low cap med cond			23-10002	

REF	DESCRIPTION	MAN. NAME	MAN. PARTNO	PARTNO	REMARKS
V12	Transistor NPN Si c/w mtg kits	Phillips	HD135	HD135	
V13	Transistor NPN Si c/w mtg kits	Phillips	BD675	BD675	
V14	Transistor NPN	Phillips	BC548	BC548	
V15	Diode Zener Si 6,8V	Phillips	BZX79-C6V8	BZX79C6V8	
V16	Diode Zener Si 5,6V	Phillips	BZX79-C5V6	BZX79C5V6	
V17	Diode Zener Si 5,1V		1N5338B	1N5338B	

Transformer Output
 Con Transistor Screen
 Phillips
 T05
 08-01915
 30-06000-001

Transformer Output
 ASSEMBLY 08-01915
 PCB 07-00378

REF	DESCRIPTION	MAN. NAME	MAN. PARTNO	PARTNO	REMARKS
C29	2,2n 10% 50V NPO CC Cap Ultramon		VJ1812A222KF	46-32200-280	
T4	Transformer RF			44-80088	
T6	Transformer RF			44-80096	

REF	DESCRIPTION	MAN. NAME	MAN. PARTNO	PARTNO	REMARKS
R35	15k Ohm 5%	Philips	CR25	40-41500-020	
R36	100k Ohm 5%	Philips	CR25	40-51000-020	
R37	1k Ohm 5%	Philips	CR25	40-31000-020	
R38	3,3k Ohm 5%	Philips	CR25	40-33300-020	
R39	S.O.T. 5%	Philips	CR25	40-00000-020	
K40	10k Ohm 5%	Philips	CR25	40-41000-020	
R41	1,5k Ohm 5%	Philips	CR25	40-31500-020	
R42	820 Ohm 5%	Philips	CR25	40-28200-020	
R43	1k Ohm 5%	Philips	CR25	40-31000-020	
R44	S.O.T. 5%	Philips	CR25	40-00000-020	
R45	3,3 Ohm 5%	Philips	CR25	40-03300-020	
K46	220 Ohm 5%	Philips	CR68	40-22200-050	
R47	100 Ohm 5%	Philips	CR25	40-21000-020	
K48	120 Ohm 5%	Philips	CR25	40-21200-020	
R49	100 Ohm 5%	Philips	CR25	40-21000-020	
R50	820 Ohm 5%	Philips	CR25	40-28200-020	
R51	S.O.T. 5%	Philips	CR25	40-00000-020	
R52	560 Ohm 5%	Philips	CR25	40-25600-020	
R53	S.O.T. 5%	Philips	CR25	40-00000-020	
RL1	RELAY 12V 1C/O HORI. MOUNT	OMRON	G2L-113P CR306	64-10301-120	
T1	Transformer RF			44-80087	
T2	Transformer RF			44-80074	
T3	Transformer RF			44-80103	
T8	Transformer RF			44-80097	
T9	Transformer RF			44-80099	
T10	Transformer RF			44-80098	
V2	Transistor NPN SI	Philips	BC548	BC548	
V3	Transistor NPN SI		BF199	BF199	
V4	Transistor NPN SI		BF199	BF199	
V5	Transistor NPN	Motorola	MRF220	23-20003	
V6	Transistor NPN	Motorola	MRF220	23-20003	
V7	Transistor NPN	Motorola	MRF421	23-20002	
V8	Transistor NPN	Motorola	MRF421	23-20002	
V9	Transistor PNP SI	Motorola	T1P32A	T1P32A	
V10	Transistor NPN SI	Philips	BC338	BC338	

REF	DESCRIPTION	MAN. NAME	MAN. PARTNO	PARTNO	REMARKS
D4	Diode SI fast low cap med cond			23-10002	
D5	Diode SI fast low cap med cond			23-10002	
D6	Diode SI fast low cap med cond			23-10002	
D7	Diode SI fast low cap med cond			23-10002	
D8	Diode SI fast low cap med cond			23-10002	
D9	Diode SI fast low cap med cond			23-10002	
D10	Diode SI fast low cap med cond			23-10002	
D11	Diode SI fast low cap med cond			23-10002	
D12	Diode SI fast low cap med cond			23-10002	
D13	Diode SI fast low cap med cond			23-10002	
D14	Diode SI fast low cap med cond			23-10002	
D15	Diode SI fast low cap med cond			23-10002	
D16	Diode SI fast low cap med cond			23-10002	
D17	Diode SI fast low cap med cond		1N4004	1N4004	
D18	Diode SI fast low cap med cond			23-10002	
D19	Diode SI fast low cap med cond			23-10002	
D20	Diode SI fast low cap med cond			23-10002	
D21	Diode SI fast low cap med cond			23-10002	
D22	Diode SI fast low cap med cond			23-10002	
D23	Diode SI fast low cap med cond			23-10002	
D24	Diode SI fast low cap med cond			23-10002	
D25	Diode SI fast low cap med cond			23-10002	
D26	Diode SI fast low cap med cond			23-10002	
D27	Diode SI fast low cap med cond			23-10002	
D28	Diode SI fast low cap med cond			23-10002	

L1	Inductor			44-70223	
L2	Inductor			44-70224	
L3	Inductor			44-70244	
L5	Inductor			44-70226	
L6	Inductor			44-70231	
L7	Inductor			44-70101	
L8	Inductor			44-70188	

PL1	Plug 6Way Standard Wafer	Molex	M4030-6/14, 22MM	60-00061-100	
PL2	Plug 4Way Standard Wafer	Molex	M4030-4/14, 22MM	60-00041-100	
PL3	Plug 10Way Standard Wafer	Molex	M4030-10/14, 22MM	60-00101-100	

REF	DESCRIPTION	MAN. NAME	MAN. PARTNO	PARTNO	REMARKS
C1	270P 5% 500V N750 CE Cap	KCK	CCH 150	46-22700-021	
C2	390P 5% 500V N750 CE Cap	Phillips	CCH	46-23900-021	
C3	390P 5% 500V N750 CE Cap	Phillips	CCH	46-23900-021	
C4	220P 5% 500V N750 CE Cap	Phillips	CCH	46-22200-021	
C5	390P 5% 500V N750 CE Cap	Phillips	CCH	46-23900-021	
C6	390P 5% 500V N750 CE Cap	Phillips	CCH	46-23900-021	
C7	390P 5% 500V N750 CE Cap	Phillips	CCH	46-23900-021	
C8	390P 5% 500V N750 CE Cap	Phillips	CCH	46-23900-021	
C9	390P 5% 500V N750 CE Cap	Phillips	CCH	46-23900-021	
C10	220P 5% 500V N750 CE Cap	Phillips	CCH	46-22200-021	
C11	220P 5% 500V N750 CE Cap	Phillips	CCH	46-22200-021	
C12	390P 5% 500V N750 CE Cap	Phillips	CCH	46-23900-021	
C13	270P 5% 500V N750 CE Cap	KCK	CCH 150	46-22700-021	
C14	180P 5% 500V N750 CE Cap	Phillips	CCH	46-21800-021	
C15	390P 5% 500V N750 CE Cap	Phillips	CCH	46-23900-021	
C16	120P 5% 500V N750 CE Cap	Phillips	CCH	46-21200-021	
C17	120P 5% 500V N750 CE Cap	Phillips	CCH	46-21200-021	
C18	120P 5% 500V N750 CE Cap	Phillips	CCH	46-21200-021	
C19	270P 5% 500V N750 CE Cap	KCK	CCH 150	46-22700-021	
C20	120P 5% 500V N750 CE Cap	Phillips	CCH	46-21200-021	
C21	68P 5% 500V N750 CE Cap	Phillips	CCH 80	46-16800-021	
C22	180P 5% 500V N750 CE Cap	Phillips	CCH	46-21800-021	
C23	150P 5% 500V N750 CE Cap	Phillips	CCH	46-21500-021	
C24	27P 5% 500V N750 CE Cap	KCK	CCH 80	46-12700-021	
C25	82P 2% 100V N750 CE Cap	Phillips	2222-632-58829	46-18200-013	
C26	1,8n 5% 125V PS Cap	Phillips	2222-425-21802	46-31800-310	
C27	1,5n 5% 125V PS Cap	Phillips	2222-425-21502	46-31500-310	
C28	6,8n 5% 63V PS Cap	Phillips	2222-424-26802	46-36800-300	
C29	2,2n 5% 125V PS Cap	Phillips	2222-425-22202	46-32200-310	
C30	1n 5% 125V PS Cap	Phillips	2222-425-21002	46-31000-310	
C31	47n 63V CE Cap	Sawwha	TL	46-44700-210	
C32	47n 63V CE Cap	Sawwha	TL	46-44700-210	
C33	1u 20% 35V TA Cap	ITT	TAG	47-01003-510	
D1	Diode Si fast low cap med cond			23-10002	
D2	Diode Si fast low cap med cond			23-10002	
D3	Diode Si fast low cap med cond			23-10002	

REF	DESCRIPTION	MAN. NAME	MAN. PARTNO	PARTNO	REMARKS
R33	4,7k Ohm 5% 0,33W	Phillips	CR25	40-34700-020	
R34	4,7k Ohm 5% 0,33W	Phillips	CR25	40-34700-020	
R35	4,7k Ohm 5% 0,33W	Phillips	CR25	40-34700-020	
R36	4,7k Ohm 5% 0,33W	Phillips	CR25	40-34700-020	
R37	4,7k Ohm 5% 0,33W	Phillips	CR25	40-34700-020	
R38	4,7k Ohm 5% 0,33W	Phillips	CR25	40-34700-020	
R39	4,7k Ohm 5% 0,33W	Phillips	CR25	40-34700-020	
R40	4,7k Ohm 5% 0,33W	Phillips	CR25	40-34700-020	
RLC	Relay 12v DC CR320 1C/0	Fuji	RL DC 12v	64-10301-122	
RLD	Relay 12v DC CR320 1C/0	Fuji	RL DC 12v	64-10301-122	
RLE	Relay 12v DC CR320 1C/0	Fuji	RL DC 12v	64-10301-122	
RLF	Relay 12v DC CR320 1C/0	Fuji	RL DC 12v	64-10301-122	
RLG	Relay 12v DC CR320 1C/0	Fuji	RL DC 12v	64-10301-122	
V1	Transistor PNP SI	Phillips	BC558	BC558	
V2	Transistor PNP SI	Phillips	BC558	BC558	
V3	Transistor PNP SI	Phillips	BC558	BC558	
V4	Transistor PNP SI	Phillips	BC558	BC558	
V5	Transistor PNP SI	Phillips	BC558	BC558	
V6	Transistor PNP SI	Phillips	BC558	BC558	
V7	Transistor PNP SI	Phillips	BC328	BC328	
V8	Transistor PNP SI	Phillips	BC558	BC558	
V9	Transistor NPN	Phillips	BC548	BC548	
V10	Transistor NPN	Phillips	BC548	BC548	
V11	Fet Junction P Channel		2N5461	2N5461	
V12	Fet Junction P Channel		2N5461	2N5461	
V13	Transistor NPN	Phillips	BC548	BC548	
V14	Transistor PNP SI	Phillips	BC558	BC558	
V15	Transistor PNP SI	Phillips	BC558	BC558	
V16	Transistor PNP SI	Phillips	BC558	BC558	
V17	Transistor PNP SI	Phillips	BC558	BC558	

REF	DESCRIPTION	MAN. NAME	MAN. PARTNO	PARTNO	REMARKS
PL4	Plug 10Way Standard Wafer	Molex	M4030-10/14,22MM	60-00101-100	
PL5	Plug 10Way Standard Wafer	Molex	M4030-10/14,22MM	60-00101-100	
PL6	Plug 10Way Standard Wafer	Molex	M4030-10/14,22MM	60-00101-100	
PL7	Plug 6Way Standard Wafer	Molex	M4030-6/14,22MM	60-00061-100	
PL8	Plug 4Way Standard Wafer	Molex	M4030-4/14,22MM	60-00041-100	
R1	470 Ohm 5% 0,5W	CF Res	CR37	40-24700-030	
R2	4,7k Ohm 5% 0,33W	CF Res	CR25	40-34700-020	
R3	4,7k Ohm 5% 0,33W	CF Res	CR25	40-34700-020	
R4	4,7k Ohm 5% 0,33W	CF Res	CR25	40-34700-020	
R5	4,7k Ohm 5% 0,33W	CF Res	CR25	40-34700-020	
R6	4,7k Ohm 5% 0,33W	CF Res	CR25	40-34700-020	
R7	4,7k Ohm 5% 0,33W	CF Res	CR25	40-34700-020	
R8	22 Ohm 5% 0,33W	CF Res	CR25	40-12200-020	
R9	22 Ohm 5% 0,33W	CF Res	CR25	40-12200-020	
R10	4,7k Ohm 5% 0,33W	CF Res	CR25	40-34700-020	
R11	4,7k Ohm 5% 0,33W	CF Res	CR25	40-34700-020	
R12	4,7k Ohm 5% 0,33W	CF Res	CR25	40-34700-020	
R13	4,7k Ohm 5% 0,33W	CF Res	CR25	40-34700-020	
R14	4,7k Ohm 5% 0,33W	CF Res	CR25	40-34700-020	
R15	4,7k Ohm 5% 0,33W	CF Res	CR25	40-34700-020	
R16	100 Ohm 5% 0,5W	CF Res	CR37	40-21000-030	
R17	2,7k Ohm 5% 0,33W	CF Res	CR25	40-32700-020	
R18	220 Ohm 5% 0,67W	CF Res	CR52	40-22200-040	
R19	4,7k Ohm 5% 0,33W	CF Res	CR25	40-34700-020	
R20	4,7k Ohm 5% 0,33W	CF Res	CR25	40-34700-020	
R21	3,3k Ohm 5% 0,33W	CF Res	CR25	40-33300-020	
R22	10k Ohm 5% 0,33W	CF Res	CR25	40-41000-020	
R23	10k Ohm 5% 0,33W	CF Res	CR25	40-41000-020	
R24	5.0.T. 5% 0,33W	CF Res	CR25	40-00000-020	
R25	10k Ohm 5% 0,33W	CF Res	CR25	40-41000-020	
R26	39k Ohm 5% 0,33W	CF Res	CR25	40-43900-020	
R27	39k Ohm 5% 0,33W	CF Res	CR25	40-43900-020	
R28	10k Ohm 5% 0,33W	CF Res	CR25	40-41000-020	
R29	10k Ohm 5% 0,33W	CF Res	CR25	40-41000-020	
R30	10k Ohm 5% 0,33W	CF Res	CR25	40-41000-020	
R31	10k Ohm 5% 0,33W	CF Res	CR25	40-41000-020	
R32	10k Ohm 5% 0,33W	CF Res	CR25	40-41000-020	

REF	DESCRIPTION	MAN. NAME	MAN. PARTNO	PARTNO	REMARKS
R8	390k Ohm 5% 0,33W	CF Res Phillips	CR25	40-53900-020	
R9	100k Ohm 2% 0,5W	MF Res Phillips	MR30	40-51000-510	
R10	91k Ohm 2% 0,5W	MF Res Phillips	MR30	40-49100-510	
R11	1M Ohm 5% 0,33W	CF Res Phillips	CR25	40-61000-020	
R12	33k Ohm 5% 0,33W	CF Res Phillips	CR25	40-43300-020	
R13	470k Ohm 5% 0,33W	CF Res Phillips	CR25	40-54700-020	
R14	1M Ohm 5% 0,33W	CF Res Phillips	CR25	40-61000-020	
R15	2,2k Ohm 5% 0,33W	CF Res Phillips	CR25	40-32200-020	
R16	100k Ohm 5% 0,33W	CF Res Phillips	CR25	40-51000-020	
R17	S.O.T.	CF Res Phillips	CR25	40-00000-020	
R18	1,5k Ohm 5% 0,33W	CF Res Phillips	CR25	40-31500-020	
R19	100k Ohm 5% 0,33W	CF Res Phillips	CR25	40-51000-020	
R21	1M Ohm 5% 0,33W	CF Res Phillips	CR25	40-61000-020	
R22	120k Ohm 5% 0,33W	CF Res Phillips	CR25	40-51200-020	
R23	3,3M Ohm 10% 0,33W	CF Res Phillips	CR25	40-63300-020	
R24	560k Ohm 5% 0,33W	CF Res Phillips	CR25	40-55600-020	
R25	150k Ohm 2% 0,5W	MF Res Phillips	MR30	40-51500-510	
R26	150k Ohm 2% 0,5W	MF Res Phillips	MR30	40-51500-510	
R27	1M Ohm 5% 0,33W	CF Res Phillips	CR25	40-61000-020	
R28	220k Ohm 2% 0,5W	MF Res Phillips	MR30	40-52200-510	
R29	240k Ohm 2% 0,5W	MF Res Phillips	MR30	40-52400-510	
R30	1M Ohm 5% 0,33W	CF Res Phillips	CR25	40-61000-020	
R31	33k Ohm 5% 0,33W	CF Res Phillips	CR25	40-43300-020	
R32	470k Ohm 5% 0,33W	CF Res Phillips	CR25	40-54700-020	
R33	1M Ohm 5% 0,33W	CF Res Phillips	CR25	40-61000-020	
R34	2,2k Ohm 5% 0,33W	CF Res Phillips	CR25	40-32200-020	
R35	100k Ohm 5% 0,33W	CF Res Phillips	CR25	40-51000-020	
R36	2,2k Ohm 5% 0,33W	CF Res Phillips	CR25	40-32200-020	
R37	1M Ohm 5% 0,33W	CF Res Phillips	CR25	40-61000-020	
R38	2,7M Ohm 10% 0,33W	CF Res Phillips	CR25	40-62700-020	
R39	10k Ohm 5% 0,33W	CF Res Phillips	CR25	40-41000-020	
R40	470k Ohm 5% 0,33W	CF Res Phillips	CR25	40-54700-020	
R41	1M Ohm 5% 0,33W	CF Res Phillips	CR25	40-61000-020	
RV1	Potentiometer Vert Trim Lin 10k	CF Res Phillips	CR25	42-41078-000	
IC1	Operational Amplifier Quad	IC National	LM3900N	XA-03900-000	
IC2	Operational Amplifier Quad	IC National	LM3900N	XA-03900-000	
IC3	Operational Amplifier Quad	IC National	LM3900N	XA-03900-000	
V5	Pat Junction P Channel		2N5461	2N5461	

REF	DESCRIPTION	MAN. NAME	MAN. PARTNO	PARTNO	REMARKS
C1	10n 10% 250V PE Cap Phillips		2222-342-45103	46-41000-500	
C2	10n 10% 250V PE Cap Phillips		2222-342-45103	46-41000-500	
C3	390p 5% 250V PS Cap Phillips		2222-426-23901	46-23900-320	
C4	56p 2% 100V N150 CE Cap Phillips		2222-632-34569	46-15600-012	
C5	6,8n 5% 63V PS Cap Phillips		2222-424-26802	46-36800-300	
C6	390p 5% 250V PS Cap Phillips		2222-426-23901	46-23900-320	
C7	56p 2% 100V N150 CE Cap Phillips		2222-632-34569	46-15600-012	
C8	6,8n 5% 63V PS Cap Phillips		2222-424-26802	46-36800-300	
C9	47n 10% 250V PE Cap Phillips		2222-342-45473	46-44700-500	
C10	1u 20% 35V TA Cap ITT		TAG	47-01003-510	
C11	47n 10% 250V PE Cap Phillips		2222-342-45473	46-44700-500	
C12	47n 10% 250V PE Cap Phillips		2222-342-45473	46-44700-500	
C13	1,2n 5% 125V PS Cap Phillips		2222-425-21202	46-31200-310	
C14	150p 2% 100V N150 CE Cap Phillips		2222-632-34151	46-21500-012	
C15	6,8n 5% 63V PS Cap Phillips		2222-424-26802	46-36800-300	
C16	1,2n 5% 125V PS Cap Phillips		2222-425-21202	46-31200-310	
C17	150p 2% 100V N150 CE Cap Phillips		2222-632-34151	46-21500-012	
C18	6,8n 5% 63V PS Cap Phillips		2222-424-26802	46-36800-300	
C19	47n 10% 250V PE Cap Phillips		2222-342-45473	46-44700-500	
C20	2,2u 20% 35V TA Cap ITT		TAG	47-02203-510	
C21	2,2u 20% 35V TA Cap ITT		TAG	47-02203-510	
D1	Diode Si fast low cap med cond			23-10002	
D2	Diode Si fast low cap med cond			23-10002	
D3	Diode Si fast low cap med cond			23-10002	
D4	Diode Si fast low cap med cond			23-10002	
D5	Diode Si fast low cap med cond			23-10002	
D6	Diode Si fast low cap med cond			23-10002	
R1	100k Ohm 5% 0,33W CF Res Phillips		CR25	40-51000-020	
R2	680k Ohm 5% 0,33W CF Res Phillips		CR25	40-56800-020	
R3	330k Ohm 5% 0,33W CF Res Phillips		CR25	40-53300-020	
R4	100k Ohm 5% 0,33W CF Res Phillips		CR25	40-51000-020	
R5	470k Ohm 5% 0,33W CF Res Phillips		CR25	40-54700-020	
R6	120k Ohm 2% 0,5W MF Res Phillips		MR30	40-51200-510	
R7	120k Ohm 2% 0,5W MF Res Phillips		MR30	40-51200-510	

REF	DESCRIPTION	IC	MAN. NAME	MAN. PARTNO	PARTNO	REMARKS
IC2	Operational Amplifier	National	LM741CN		XA-00741-100	
V3	Transistor PNP SI	Phillips	BC558		BC558	
V4	Transistor PNP SI	Phillips	BC328		BC328	

REF	DESCRIPTION	MAN. NAME	MAN. PARTNO	PARTNO	REMARKS
C3	330P 5% 250V PS Cap Phillips 2222-426-23301 46-23300-320				
C6	330P 5% 250V PS Cap Phillips 2222-426-23301 46-23300-320				
C7	4,7u 20% 35V TA Cap ITT TAG 47-04703-510 47-04703-510				
C8	4,7u 20% 35V TA Cap ITT TAG 47-04703-510 47-04703-510				
C9	10n 2% 63V PS Cap Phillips 2222-424-31003 46-41000-301				
C10	10n 2% 63V PS Cap Phillips 2222-424-31003 46-41000-301				
D1	Diode Si fast low cap med cond 23-10002				
D2	Diode Si fast low cap med cond 23-10002				
D3	Diode Si fast low cap med cond 23-10002				
D4	Diode Si fast low cap med cond 23-10002				
R2	100k Ohm 2% 0,5W MF Res Phillips MR30 40-51000-510				
R3	33k Ohm 5% 0,33W CF Res Phillips CR25 40-43300-020				
R5	4,7k Ohm 5% 0,33W CF Res Phillips CR25 40-34700-020				
R6	4,7k Ohm 5% 0,33W CF Res Phillips CR25 40-34700-020				
R8	68k Ohm 2% 0,5W MF Res Phillips MR30 40-46800-510				
R9	33k Ohm 5% 0,33W CF Res Phillips CR25 40-43300-020				
R11	4,7k Ohm 5% 0,33W CF Res Phillips CR25 40-34700-020				
R12	4,7k Ohm 5% 0,33W CF Res Phillips CR25 40-34700-020				
R13	82k Ohm 5% 0,33W CF Res Phillips CR25 40-48200-020				
R14	100k Ohm 5% 0,33W CF Res Phillips CR25 40-51000-020				
R15	22k Ohm 5% 0,33W CF Res Phillips CR25 40-42200-020				
R16	470 Ohm 5% 0,33W CF Res Phillips CR25 40-24700-020				
R17	10k Ohm 5% 0,33W CF Res Phillips CR25 40-41000-020				
R19	10k Ohm 5% 0,33W CF Res Phillips CR25 40-41000-020				
R1b	S.O.T. Ohm 5% 0,33W CF Res Phillips CR25 40-00000-020				
R4a	100k Ohm 2% 0,5W MF Res Phillips MR30 40-51000-510				
R4b	S.O.T. Ohm 5% 0,33W CF Res Phillips CR25 40-00000-020				
R7a	10k Ohm 5% 0,33W CF Res Phillips CR25 40-41000-020				
R7b	S.O.T. Ohm 5% 0,33W CF Res Phillips CR25 40-00000-020				
R10a	68k Ohm 2% 0,5W MF Res Phillips MR30 40-46800-510				
R10b	S.O.T. Ohm 5% 0,33W CF Res Phillips CR25 40-00000-020				

IC1 Operational Amplifier IC National LM741CN XA-00741-100

9. DRAWINGS

Main PCB Circuit Diagram	04-01182
Main PCB Layout	08-01644-001
PA & Chassis Circuit Diagram	04-01365
PA PCB Layout	08-01914
Remote Control Circuit Diagram	04-01366
Remote Control PCB	08-01946
Mute Circuit Diagram	04-00719
Mute PCB	08-01361
Emergency Call PCB	08-00889

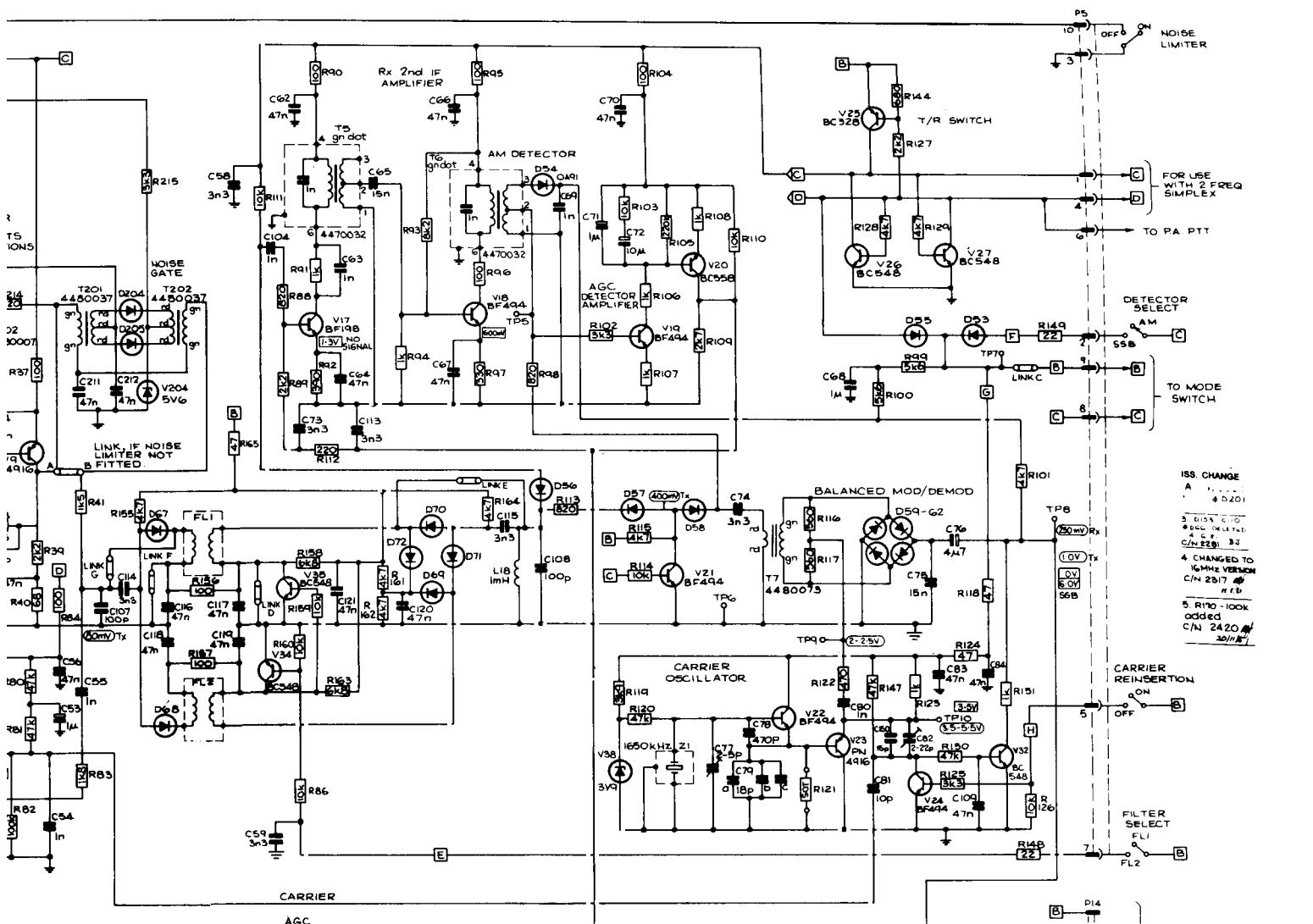

ISS CHANGE
 A
 4 D201
 3 B15K C107
 4 C21
 C125B 33
 C125B 33
 4 CHANGED TO
 16MHz VERSION
 C1N 2517 #1B
 #1B
 5 R170-100K
 added
 C1N 2420 #1
 301M/1

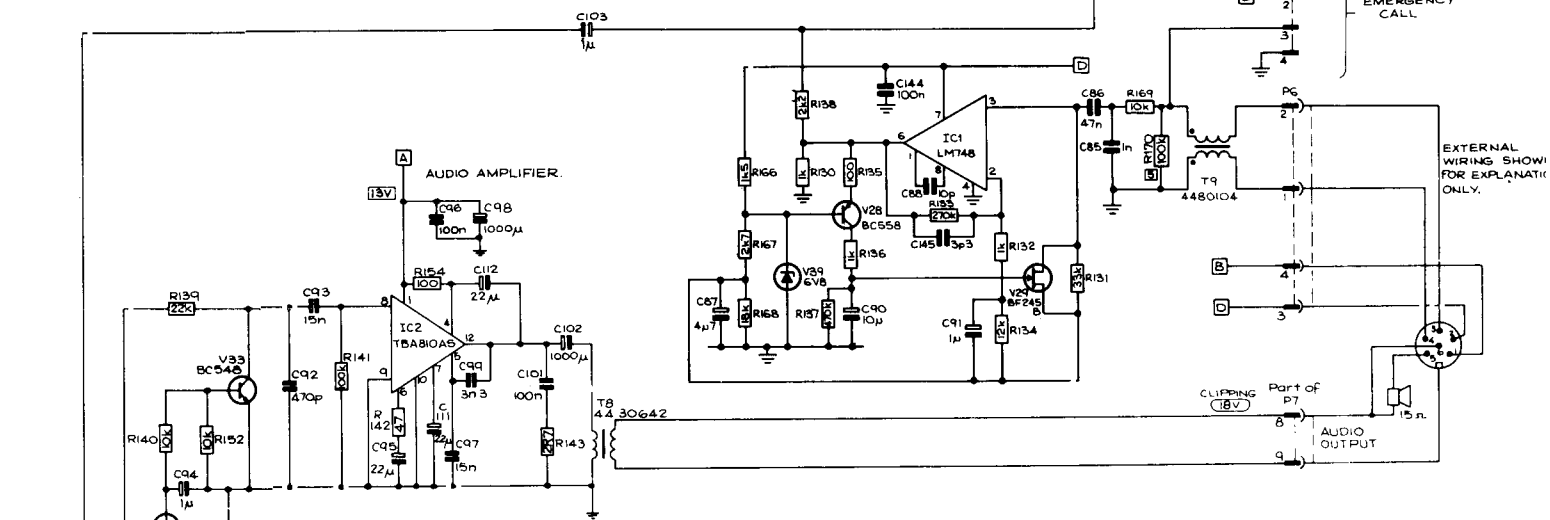

PCB 07-0057
 ASSY 08-01644-001

MODE	OPTION	FILTER	POSITION
A	AM	QFO1601	FL2
L	LSB	QFO1600	FL1 or FL2
U	USB	QFO1602	FL1

MODE OPTION	COMPONENTS FITTED
LOR ONLY	DELETE: C59, 68, 69, 82, 114, 122, D55-58, 67-72, L18, R86, 99-101, 148-151, 155-165; V32, 34, 35, C150 FIT: LINK C, D, E, F & G
LU	DELETE: C68, 69, 82, D55-58, R99-101, 149-151, V32 FIT: C150 LINK: C
A	FIT ALL COMPONENTS AS SHOWN EXCEPT C150

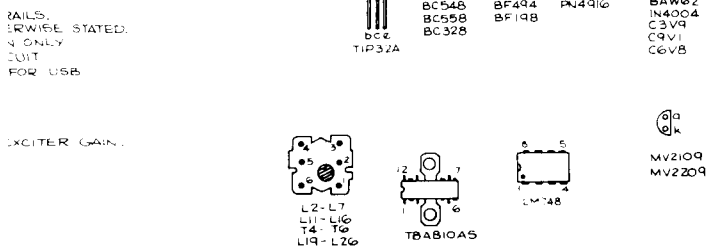

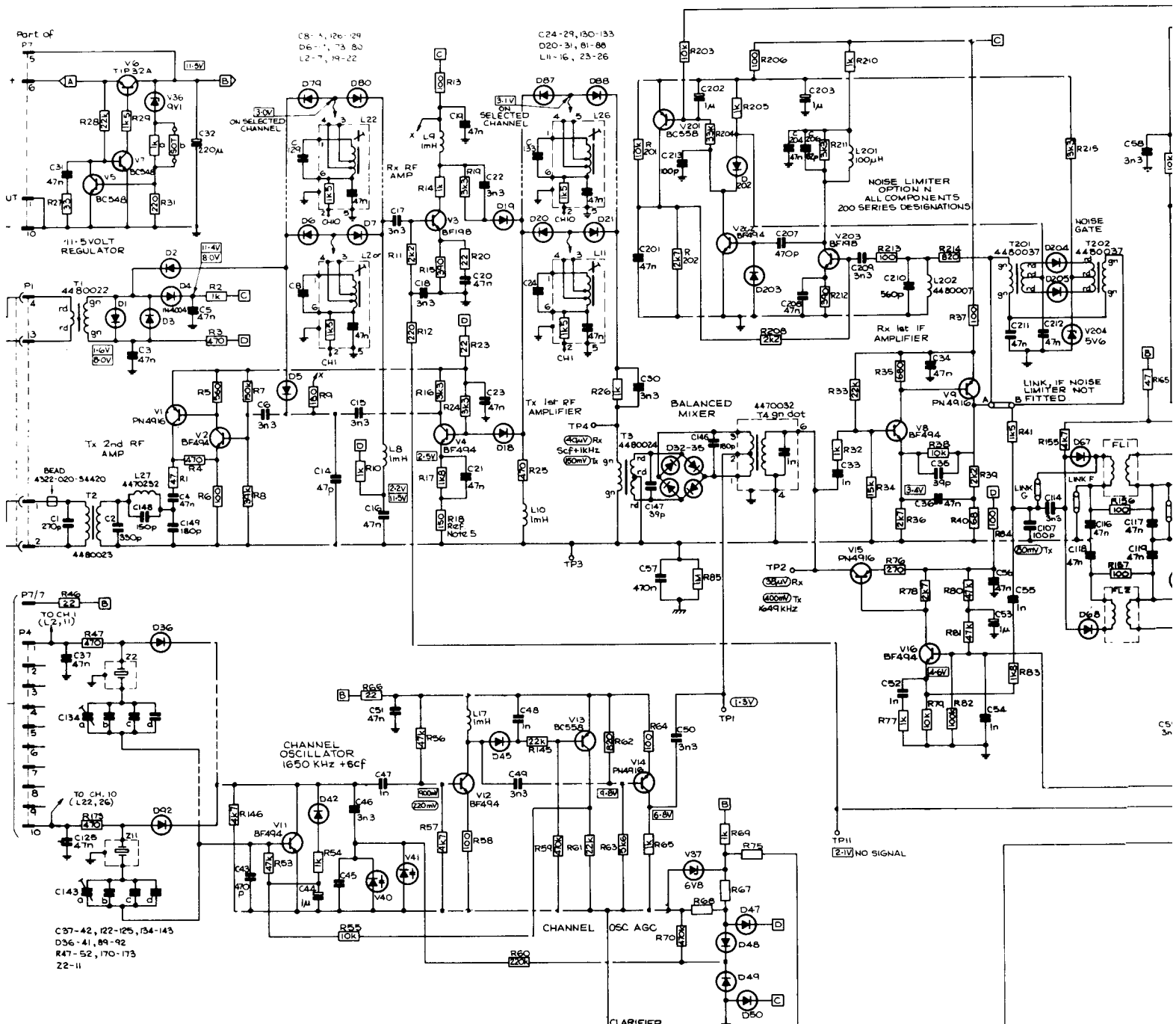

IER	C45	V40	V41	D47	D48	D49	D50	R67	R68	R72	R73	R74	R75	SPECIFICATION
TEO	82p	--	--	--	--	--	--	--	--	--	--	--	--	RB209
ALSO OMIT R60, R69, 70, 71 & Z2														
OW ONLY	39p	--	MW2109	X	X	X	X	10k	6k2	6k2	--	12k	8k2	RB209
SW Tx	39p	--	MW2109	--	--	X	--	--	6k2	--	12k	8k2	--	RB209-0
FLY	--	MW2109	MW2109	X	X	X	X	10k	6k2	LINK	33k	--	LINK	VOLUNTARY SUB-MISSION & EXPORT
FLY & Tx	--	MW2109	MW2109	--	--	X	--	--	LINK	33k	--	LINK	--	EXPORT ONLY

CONTROL RAIL VOLTAGES							
RAIL	TEST POINT	655/USB Rx	655/USB Tx	LSB Rx	LSB Tx	AM Rx	AM Tx
	SK5/9	11.5	11.5	11.5	11.5	11.5	11.5
	SK5/1	11.5	0	11.5	0	11.5	0
	SK5/6	0	11.5	0	11.5	0	11.5
	SK5/7	0	0	11.5	11.5	11.5	0
	SK5/2	11.5	0	11.5	0	0	0.6
	TP7	10.4	10.7	10.4	10.7	0	10.7
	SK5/5	11.5	11.5	11.5	11.5	11.5	0

MENT NOTES:-
 1. ALL DC VOLTAGES ARE MEASURED WITH RESPECT TO THE NEGATIVE RAIL (NO OPTIONS FITTED).
 2. VALUES ARE TYPICAL AND MAY VARY BETWEEN UNITS. SOME VOLTAGES WILL VARY WITH CHANNEL FREQUENCY.
 3. READINGS MEASURED WITH 20kΩ/V METER UNDER NO SIGNAL CONDITIONS:-
 RECEIVE MODE
 TRANSMIT MODE
 VOLTAGES MEASURED WITH AN OSCILLOSCOPE PROBE 10MΩ AND 12PF OR LOWER, 655 USB MODE EXCEPT WHERE INDICATED OTHERWISE:-
 TRANSMIT VOLTAGES IN PEAK-PEAK UNITS, WITH A SINGLE TONE APPROX 1KHz 20mVrms BALANCED, APPLIED TO THE MICROPHONE INPUT THIS CORRESPONDS TO APPROX 10dB OF COMPRESSION IN THE MICROPHONE AMP. A TWO TONE SOURCE WILL GIVE THE SAME PEAK-PEAK MEASUREMENTS IN THE EXCITER.
 RECEIVE VOLTAGES EXPRESSED AS EMF FROM A 50Ω SOURCE APPLIED VIA AC COUPLING TO THE POINT INDICATED, WHICH WILL CAUSE THE AGC VOLTAGE AT TP11 TO INCREASE BY 300mV FROM ITS NO SIGNAL VALUE IN THE RECEIVE MODE.
 VOLTAGES IN PEAK-PEAK INPUTS IN THE RECEIVE AND TRANSMIT MODES

CIRCUIT NOTES:-
 1. (C) CONTROL RAILS (D) ORIGIN OF CONTROL RAILS.
 2. ALL DIODES IN 1N41 OR EQUIVALENT, UNLESS OTHERWISE INDICATED.
 3. WIRING EXTERNAL TO PCB'S FOR EXPLANATION ONLY.
 4. FOR FURTHER INFORMATION, REF CHASSIS CIRCUIT.
 5. FREQUENCIES SHOWN AT MONITOR POINTS ARE FOR 1KHz MODULATION.
 6. RESISTOR R18 MAY BE SELECTED TO SET EXCITER GAIN.

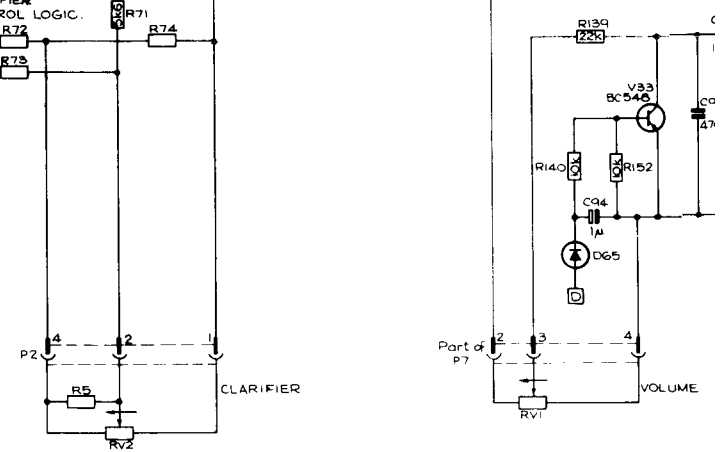

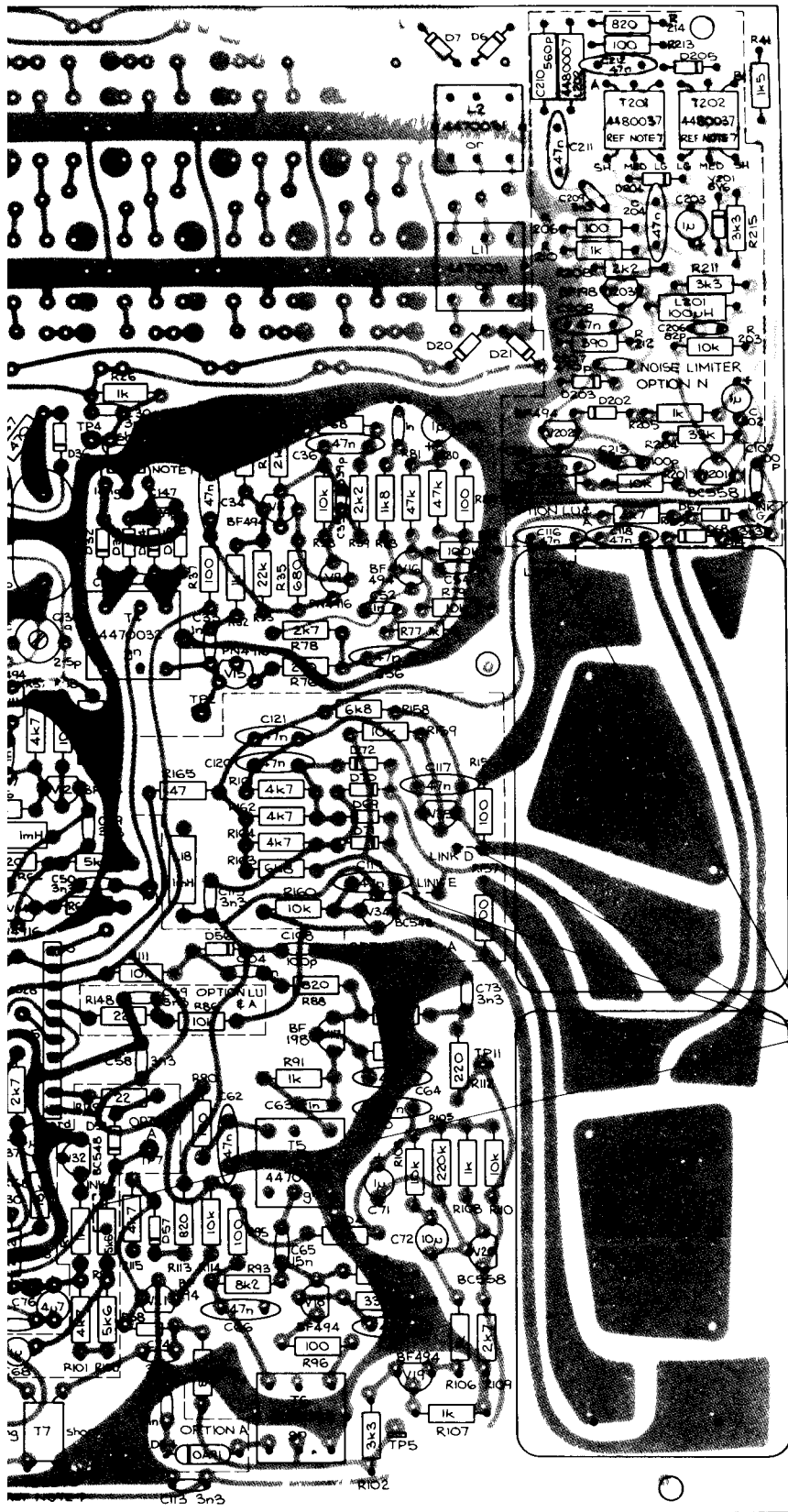

OPTION No	CODE	OPTION
15-10158	A	AM
15-10047	L	L.T.B.
15-10048	U	U.S.B.
15-10159	LU	L.S.B. & J.S.B.
15-10051		NO CLARIFIER
15-10052	CAN	NARROW R.F. ONLY
15-10053	CBN	" R.x & T.x
15-10054	CAW	WIDE R.F. ONLY
15-10055	CBW	" R.x & T.x
15-10058	N	NOISE LIMITER

TRANSFORMER		WINDINGS
T1	44-80022	ye SHORT - rd LONG - gn
T2	44-80023	gn SHORT - rd LONG - gn
T3	44-80024	bi SHORT - gn LONG - rd
T7	44-80073	dk SHORT - rd rd LONG - gn
T9	44-80104	bn SHORT - gn rd LONG - rd
T201	44-80037	dk SHORT - gn bn MEDIUM - rd
T202		

REF NOTE 8

2. R170 - 100k
added
C/N 2420 A/R
20/11/81

REF NOTE 4

17-00557 ISS. 6

NK BETWEEN A & B WHEN OPTION 'N'
 TED
 S IN 914A OR EQUIVALENT UNLESS
 OTHERWISE
 OP OF BOARD AROUND MOUNTING
 FOR FITTING FILTERS
 C, D, E, F & G WHEN OPTION 'N' RAN FETTL
 WHEN OPTION 'N' FITTL

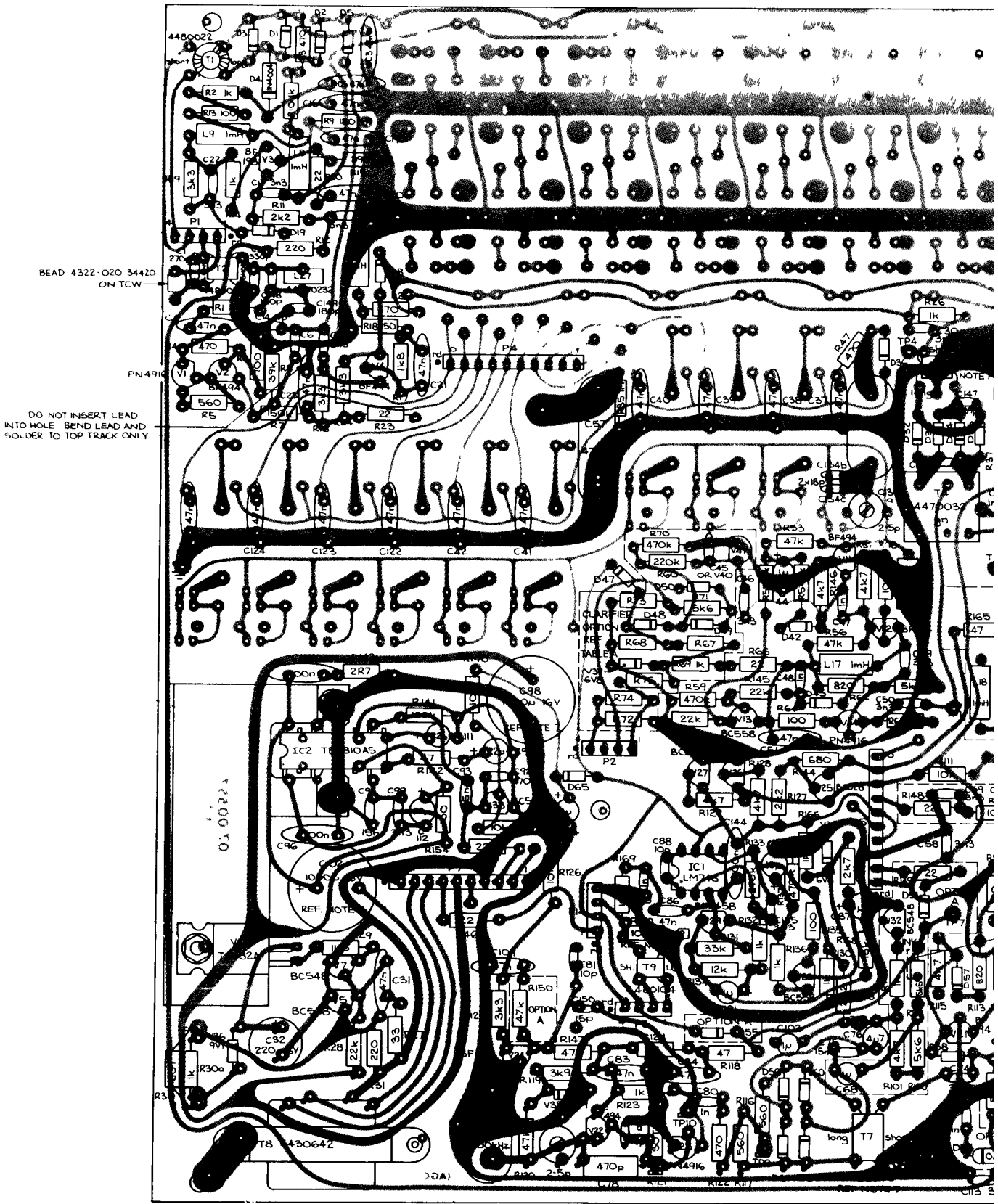

PCB 07-00557 ISS.6

- NOTES:-
- 1 FIT TCW LINK BETWEEN A & B WHEN IS NOT FITTED.
 2. ALL DIODES IN914A OR EQUIVALENT SHOWN OTHERWISE.
 3. TIN ON TOP OF BOARD AROUND M HOLES BEFORE FITTING FILTERS.
 4. FIT LINKS C,D,E,F & G WHEN OPTIO FIT LINK C WHEN OPTION 'LU' FIT

TABLE A

CODE	CLARIFIER	C45	V40	V41	D48	D49	D50	R60	R67	R68	R69	R70	R71	R72	R73	R74	R75	V37
	NOT FITTED	82p	-	-	-	-	-	-	-	-	-	-	-	-	-	-	-	-
CAN	NARROW R x ONLY	39p	-	MV2109	✓	✓	✓	✓	10k	6k8	✓	✓	✓	6k2	-	12k	8k2	✓
CBN	NARROW R x & T x	39p	-	MV2109	✓	✓	✓	✓	10k	6k8	✓	✓	✓	6k2	-	12k	8k2	✓
CAW	WIDE R x ONLY	-	MV2109	MV2109	✓	✓	✓	✓	10k	6k8	✓	✓	✓	LINK	33k	-	LINK	✓
CBW	WIDE R x & T x	-	MV2109	MV2109	✓	✓	✓	✓	10k	6k8	✓	✓	✓	LINK	33k	-	LINK	✓

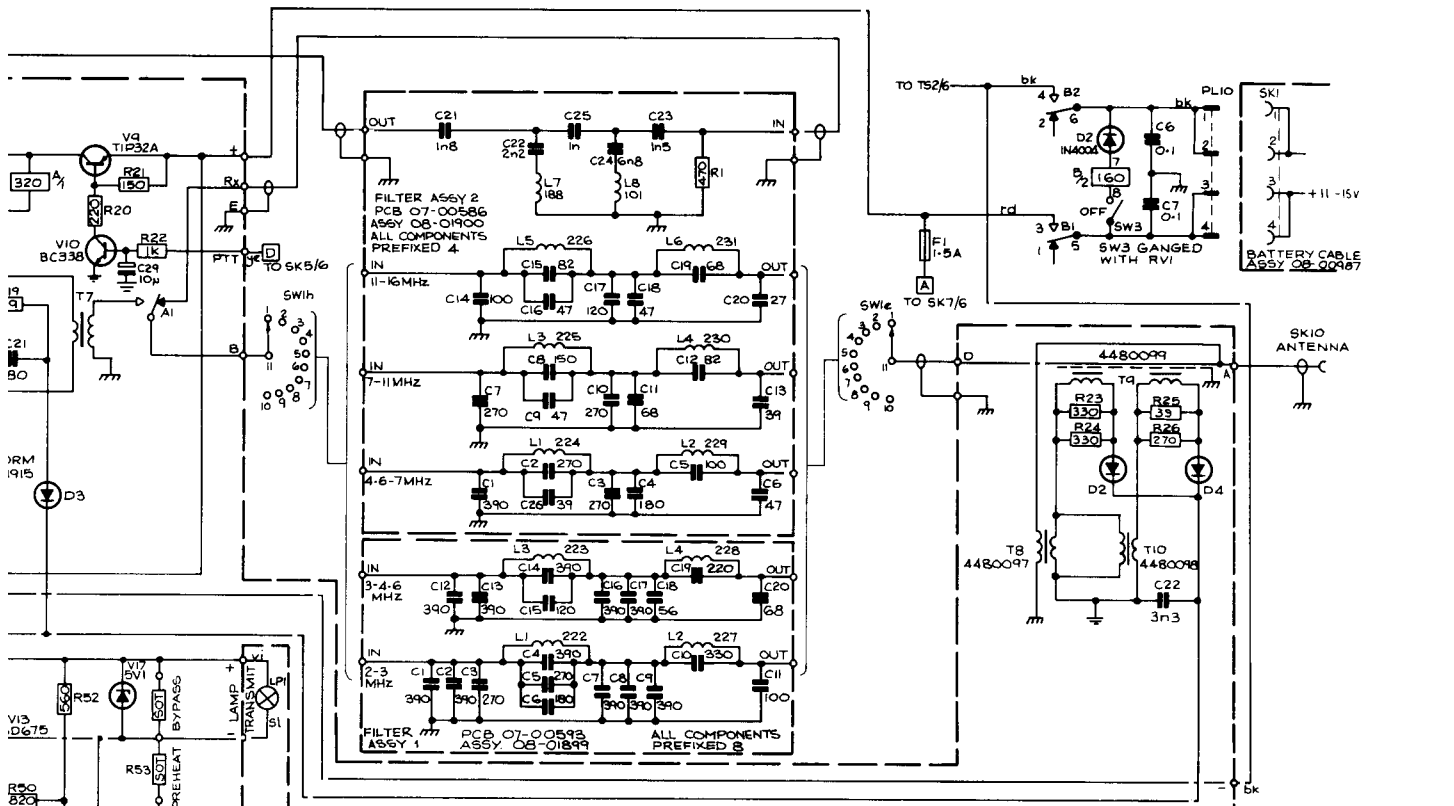

NOTE: WAFER SWIK FITTED AS STANDARD TO 14-00133 AVAILABLE AS 14-00132 FOR RETROFIT TO 14-00130

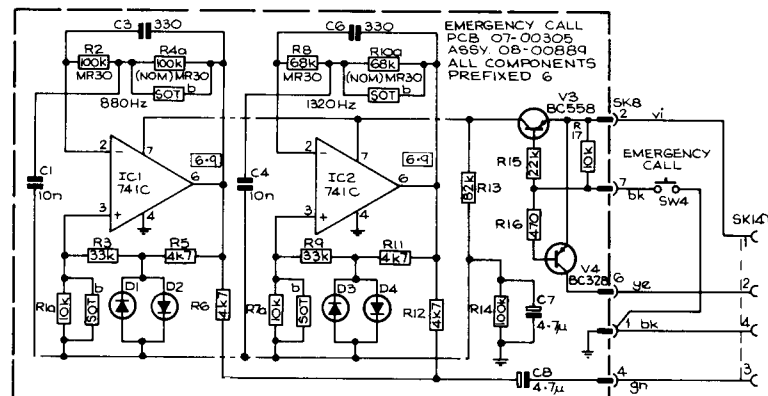
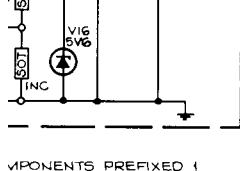
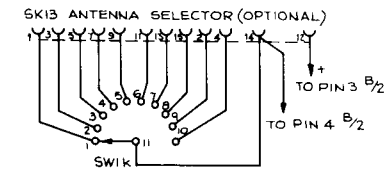

CIRCUIT NOTES:-

- 1. [D] CONTROL RAILS
- 2. ALL DIODES IN 914 OR EQUIVALENT UNLESS SHOWN OTHERWISE.

MEASUREMENT NOTES:-

- 1. ALL VOLTAGES ARE MEASURED WITH RESPECT TO THE NEGATIVE RAIL. VOLTAGES ARE TYPICAL AND MAY VARY BETWEEN UNITS.
- 2. DC VOLTAGES SHOWN [3-4] ARE MEASURED WITH A 20k Ω /V METER, AND ARE IN THE TRANSMIT MODE AND WITHOUT SIGNALS APPLIED.

NOTES:-

- 1. USE LOW CAPACITANCE PROBE TO MEASURE VOLTAGE AT V3, V4 COLLECTORS, 47pF.
- 2. USE AN EARTH AS CLOSE AS PRACTICABLE TO POINT OF MEASUREMENT. WIND EXCESS PROBE EARTH LEAD AROUND PROBE TO MINIMISE LOOP AREA.

OUTLINES: ALL DEVICES VIEWED FROM BASE UNLESS SHOWN OTHERWISE.

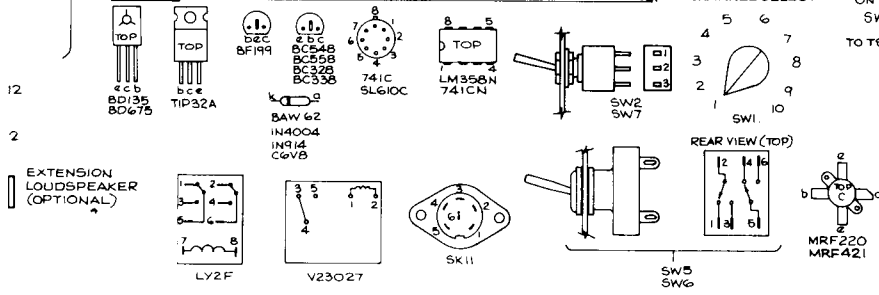

DA ASSY
PCB 07-00428
ASSY 08-01914
ALL COMPONENTS PREFIXED 3

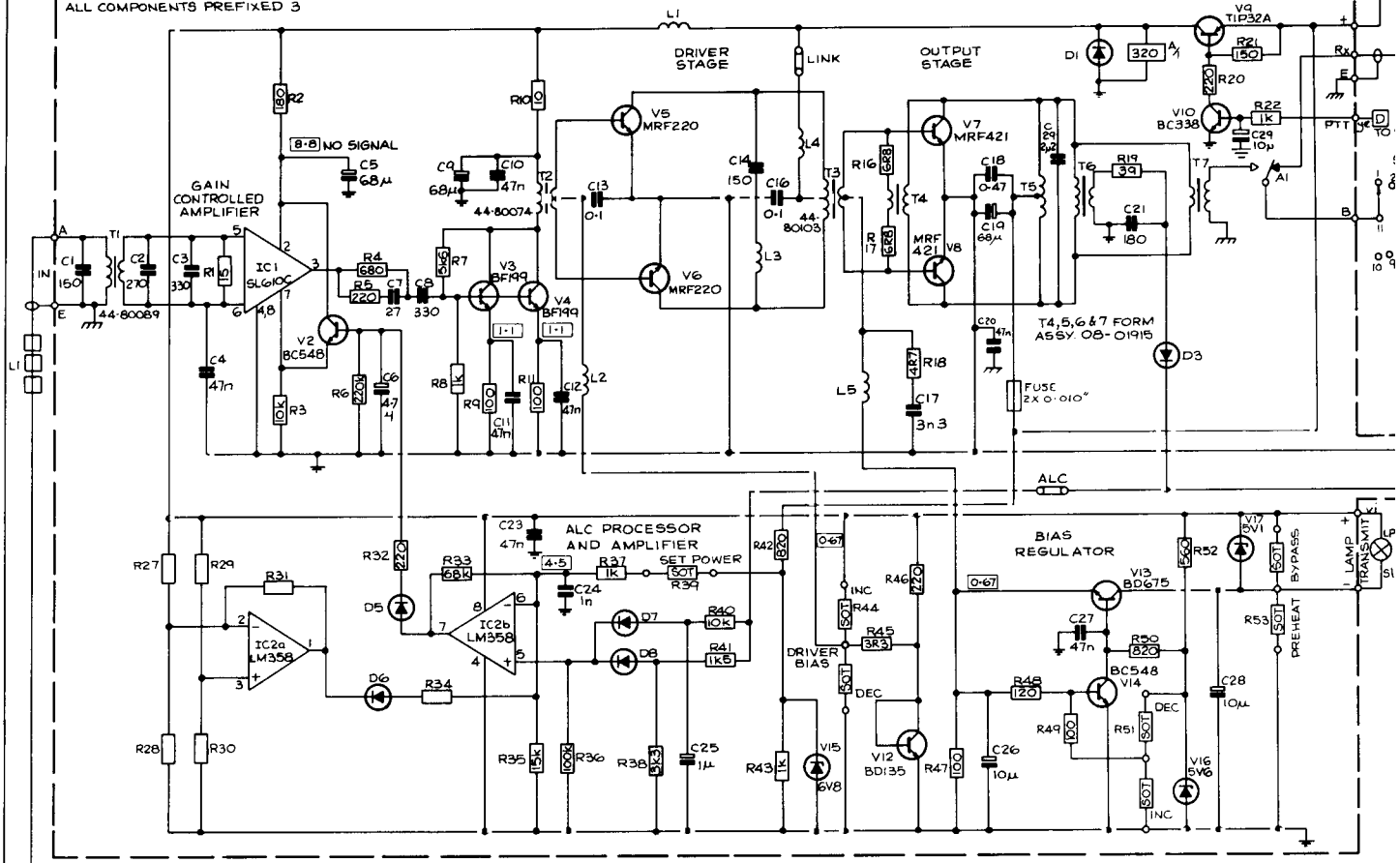

FRAME
ALL COMPONENTS PREFIXED 1

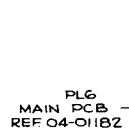
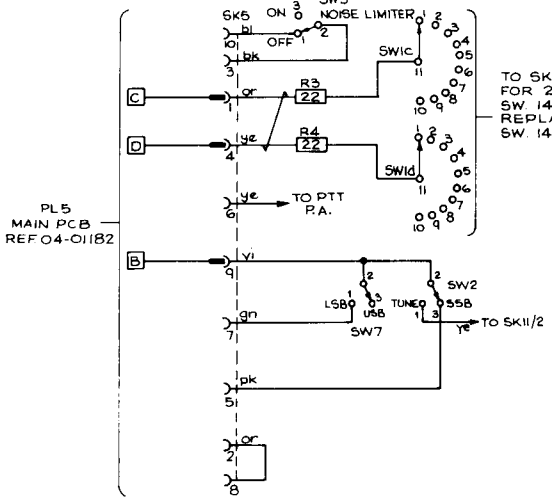
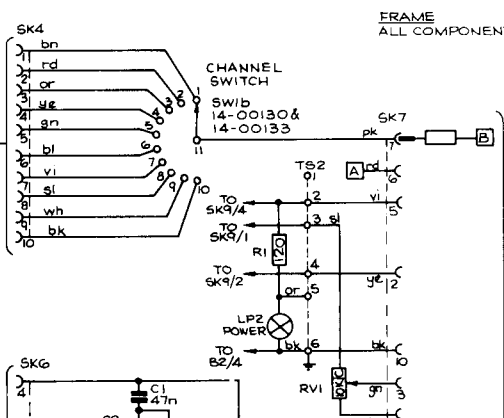
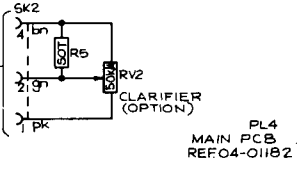
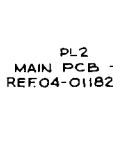
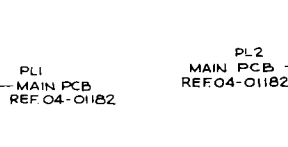

- CIRCUITRY
1. DC
 2. AC
- MEASUREMENTS
1. ALL RAIL
 2. DC
 3. AC
- NOTES
1. USE 47pF
 2. USE WINC

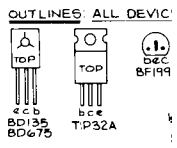

EXTENSION LOUDSPEAKER (OPTIONAL)

220Ω RESISTOR FITTED ONLY WHEN HEADPHONES USED.

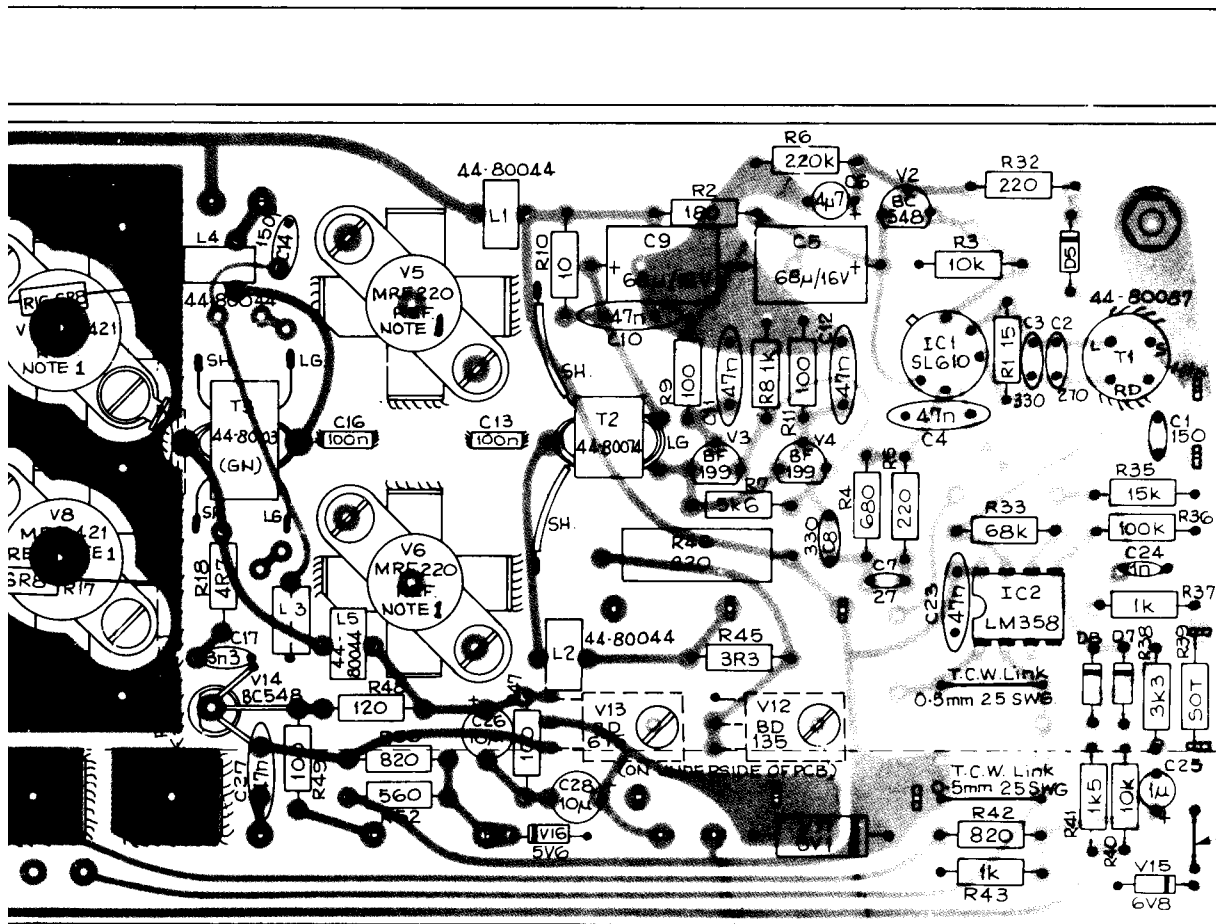

T.C.W. Link
0.5mm 25 SWG

TRANSFORMER	WINDINGS
T3	44-80103 GREEN SHORT- RD LONG- RD/GN
T8	44-80097 BLUE SHORT- GN LONG- RD
T10	44-80098 BK/ BL SHORT- GN LONG- RD
T2	44-80074 RD/ YL SHORT- RD LONG- RD
T1	44-80087 RED SHORT- GN LONG- RD

THERMAFLOW BEFORE FIXING TO HEATSINK.
 ASSOCIATED TRANSISTORS & TRANSFORMERS
 WITH 2% Ag
 WITH THERMAFLOW
 HEATSINK IS FILLED WITH THERMAFLOW

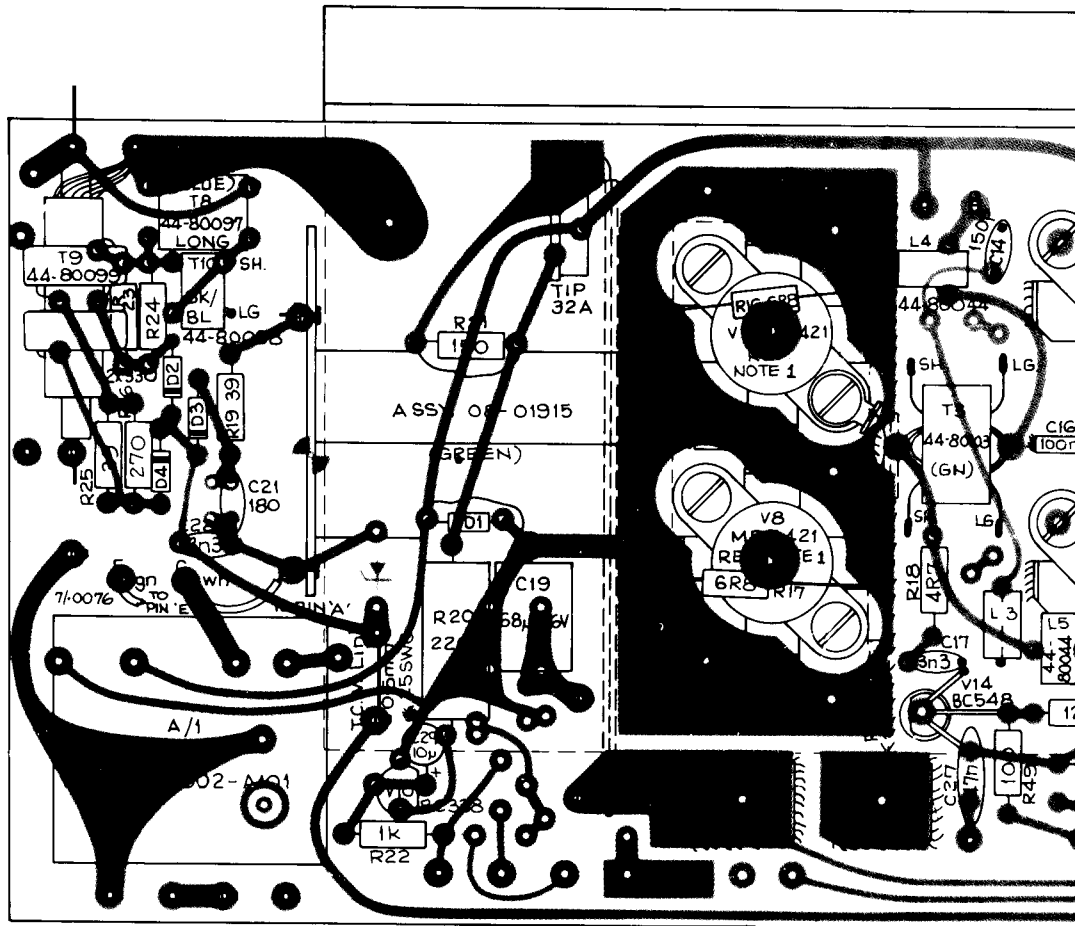

1. COAT V5-8 FLANGE WITH THERMAFLOW BEFORE FIXING TO
2. FOR SOLDERING C13, C16, C17, ASSOCIATED TRANSISTORS & TRA USE CAPALLOY 62% Sn, 36% Pb, 2% Ag.
3. COAT TOP & BOTTOM OF HEATSINK SPACER WITH THERMA BEFORE FITTING.
4. ENSURE SPACE BETWEEN V14 & HEATSINK IS FILLED WITH THERMA

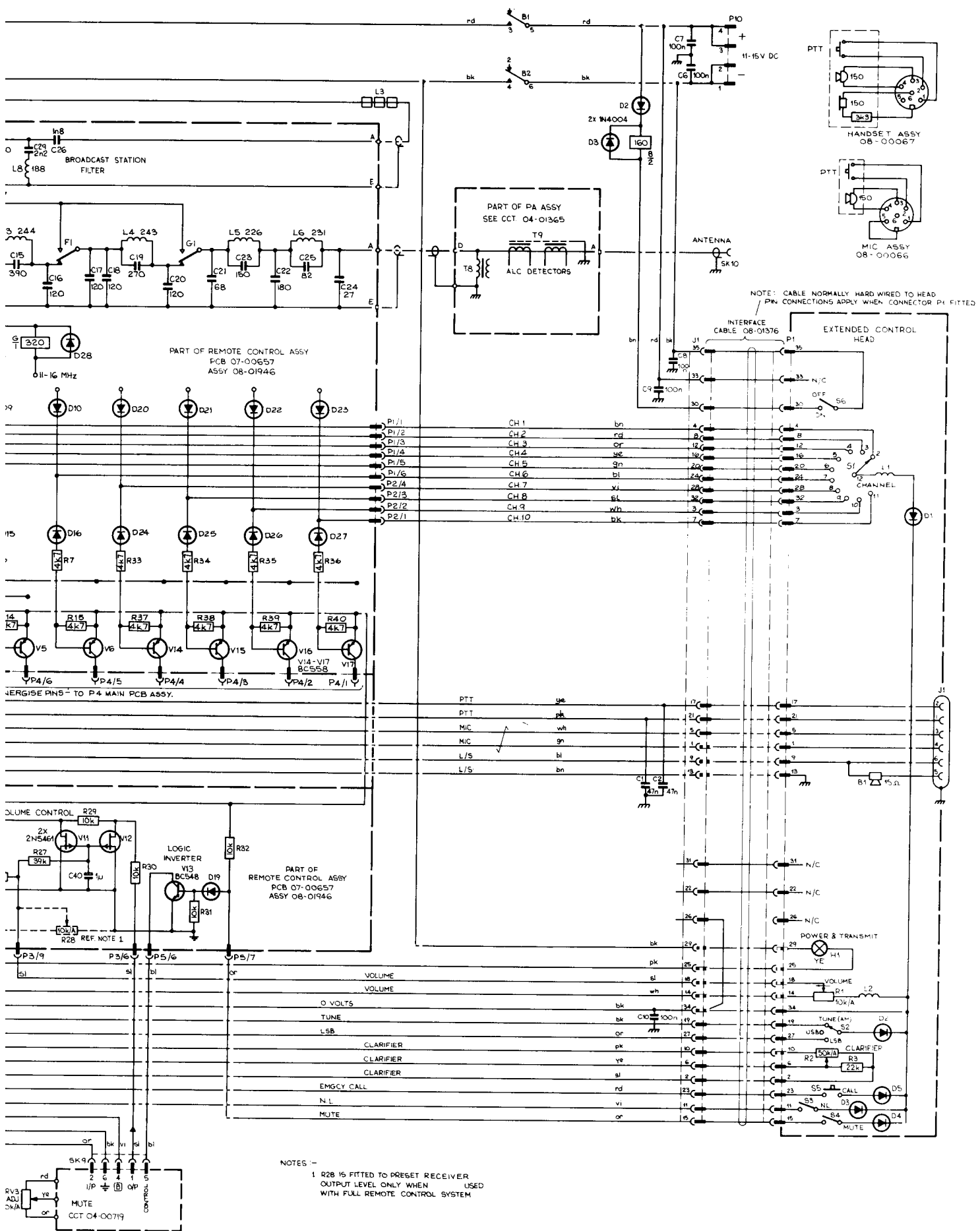

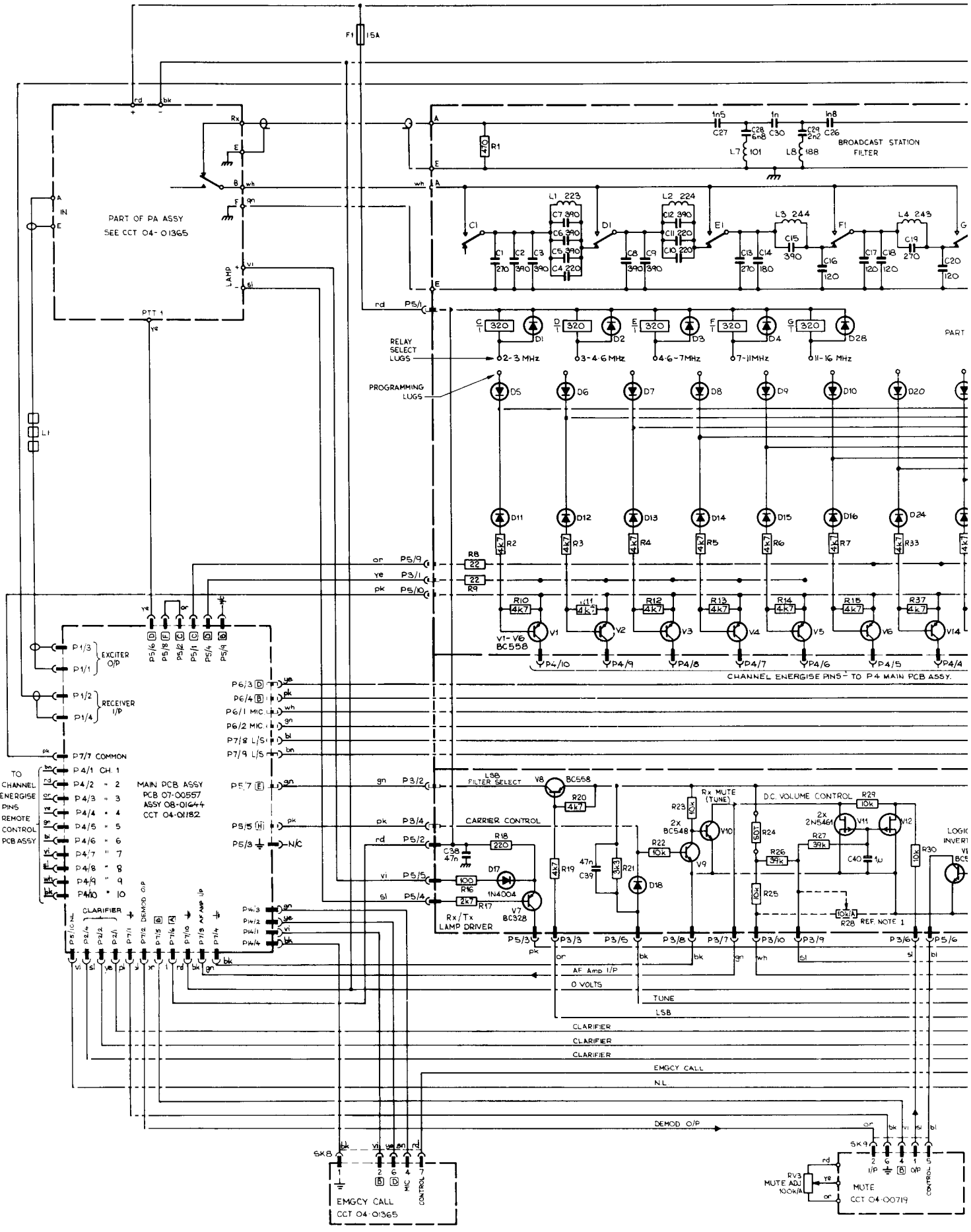

PART OF PA ASSY
SEE CCT O4-01365

BROADCAST STATION
FILTER

RELAY SELECT LUGS
PROGRAMMING LUGS

D1 0.2-3 MHz
D2 0.3-4.6 MHz
D3 0.4-6-7 MHz
D4 0.7-11 MHz
D5 0.1-16 MHz

CHANNEL ENERGISE PINS TO P4 MAIN PCB ASSY

TO CHANNEL ENERGISE PINS
REMOTE CONTROL PCB ASSY

CLARIFIER
CLARIFIER
CLARIFIER

EMGCY CALL
CCT O4-01365

MUTE
MUTE ADJ 1000Ω
MUTE
CCT O4-00719

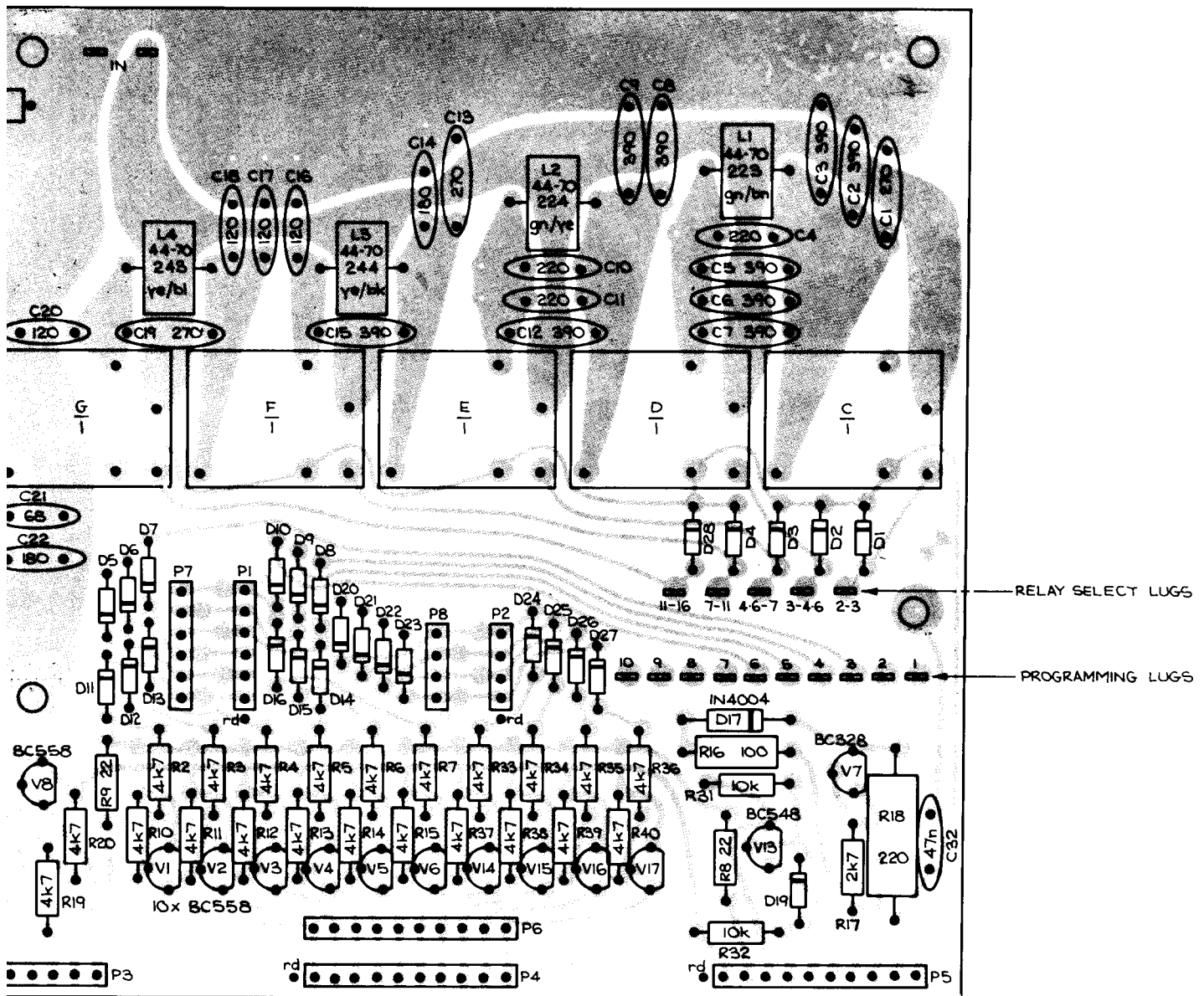

PCB 07-00657 ISS.1

NOTES:-

1. R28 IS FITTED TO PRESET R_x OUTPUT LEVEL ONLY WHEN USED WITH FULL REMOTE CONTROL SYSTEM.

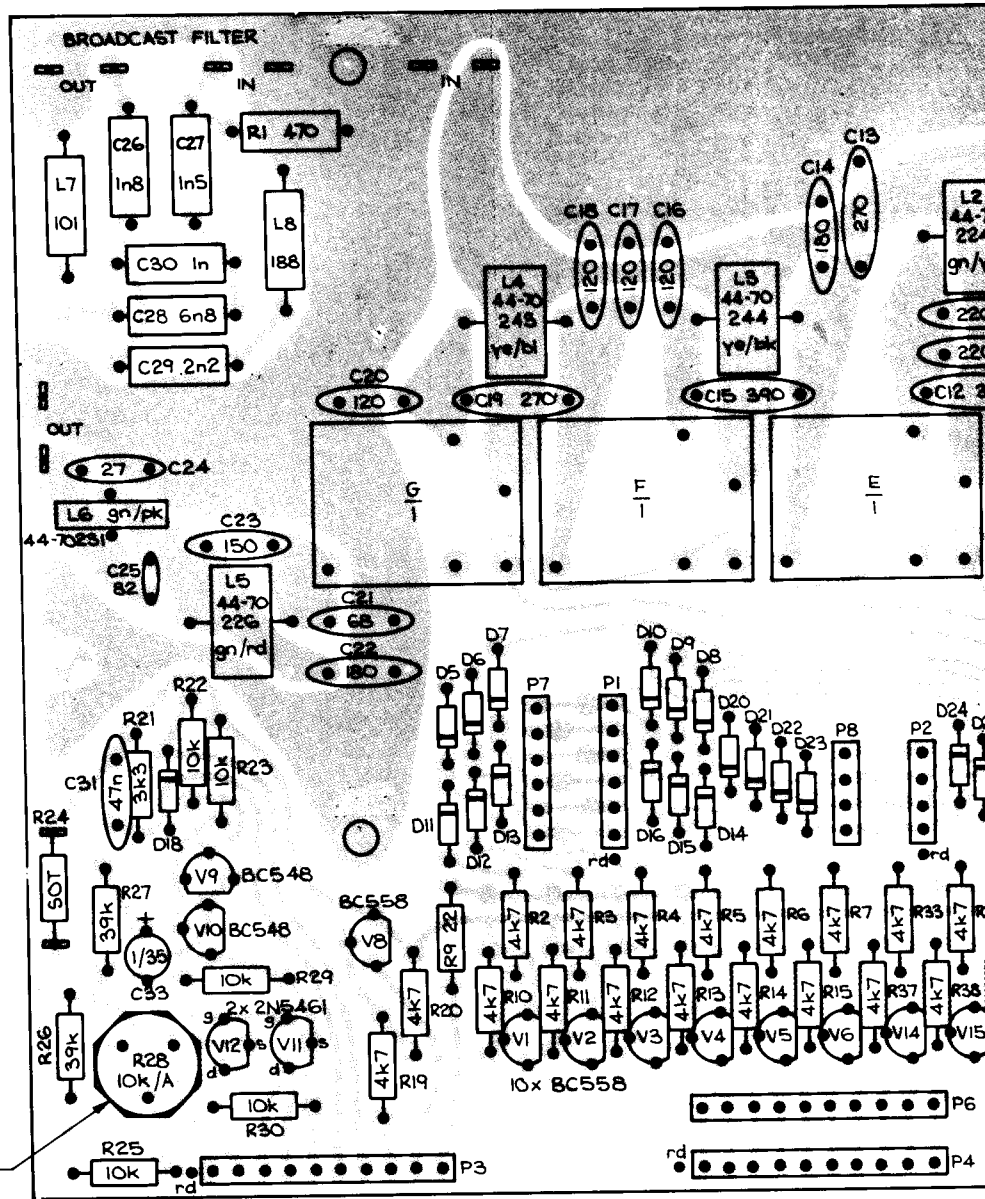

PCB 07-00657 ISS.1

NOTES:-

1. R28 IS FITTED TO PRESET R_x OUTPUT LEVEL ONLY WHEN USED WITH FULL REMOTE CONTROL SYSTEM.

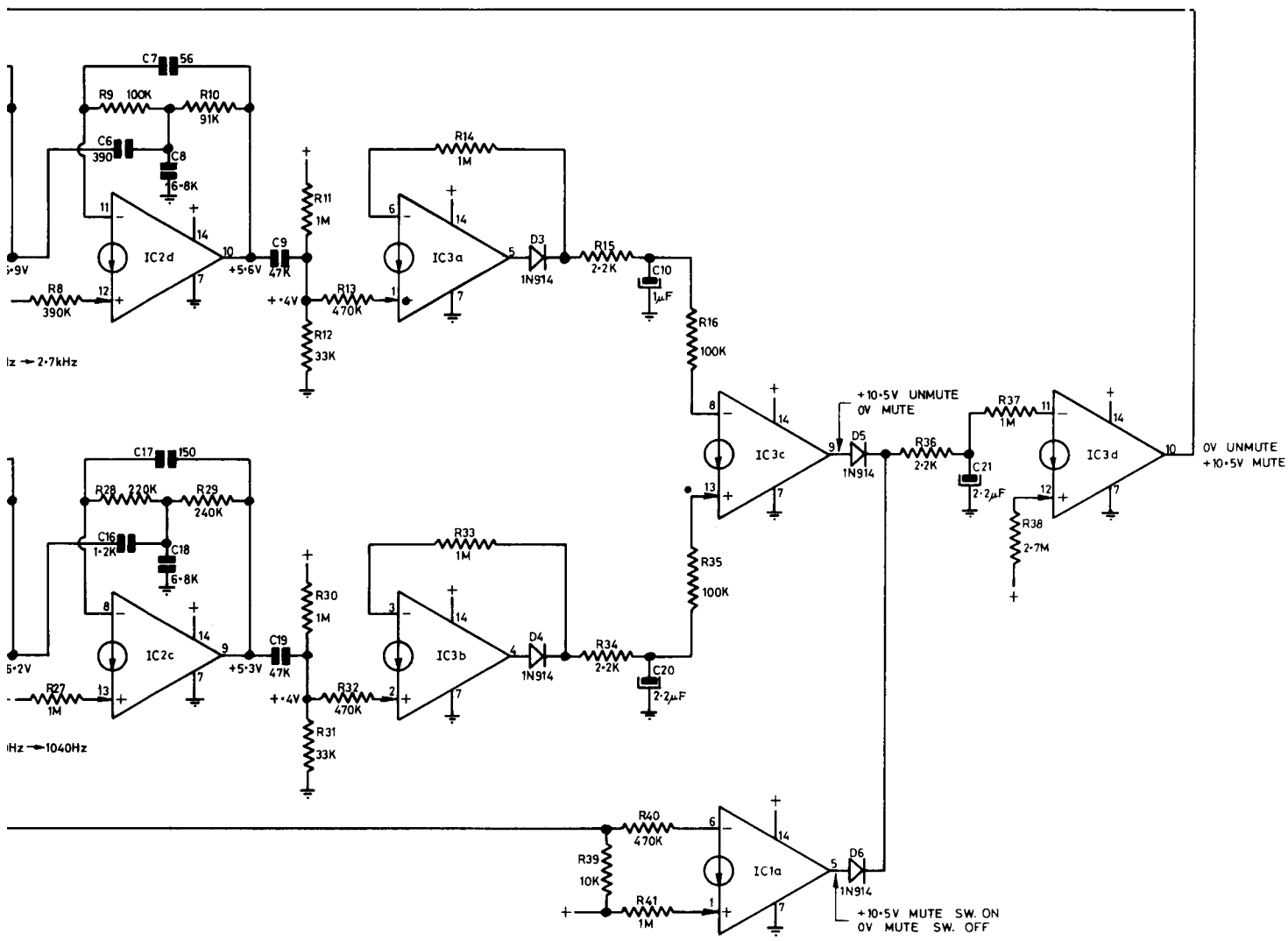

MUTE 04-00719 ISS. 4

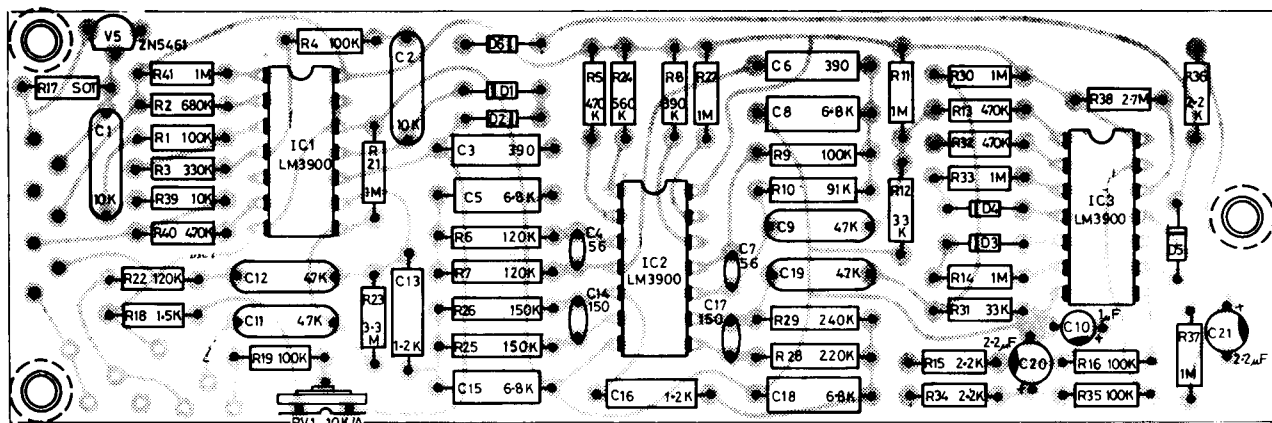

PCB.07-00331 ISS. 1.

MUTE P.C.B. ASSY. 08-01361 ISS. 2

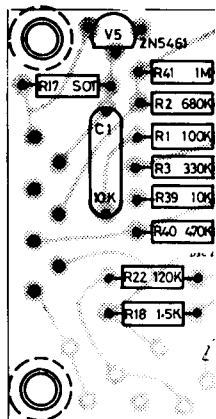
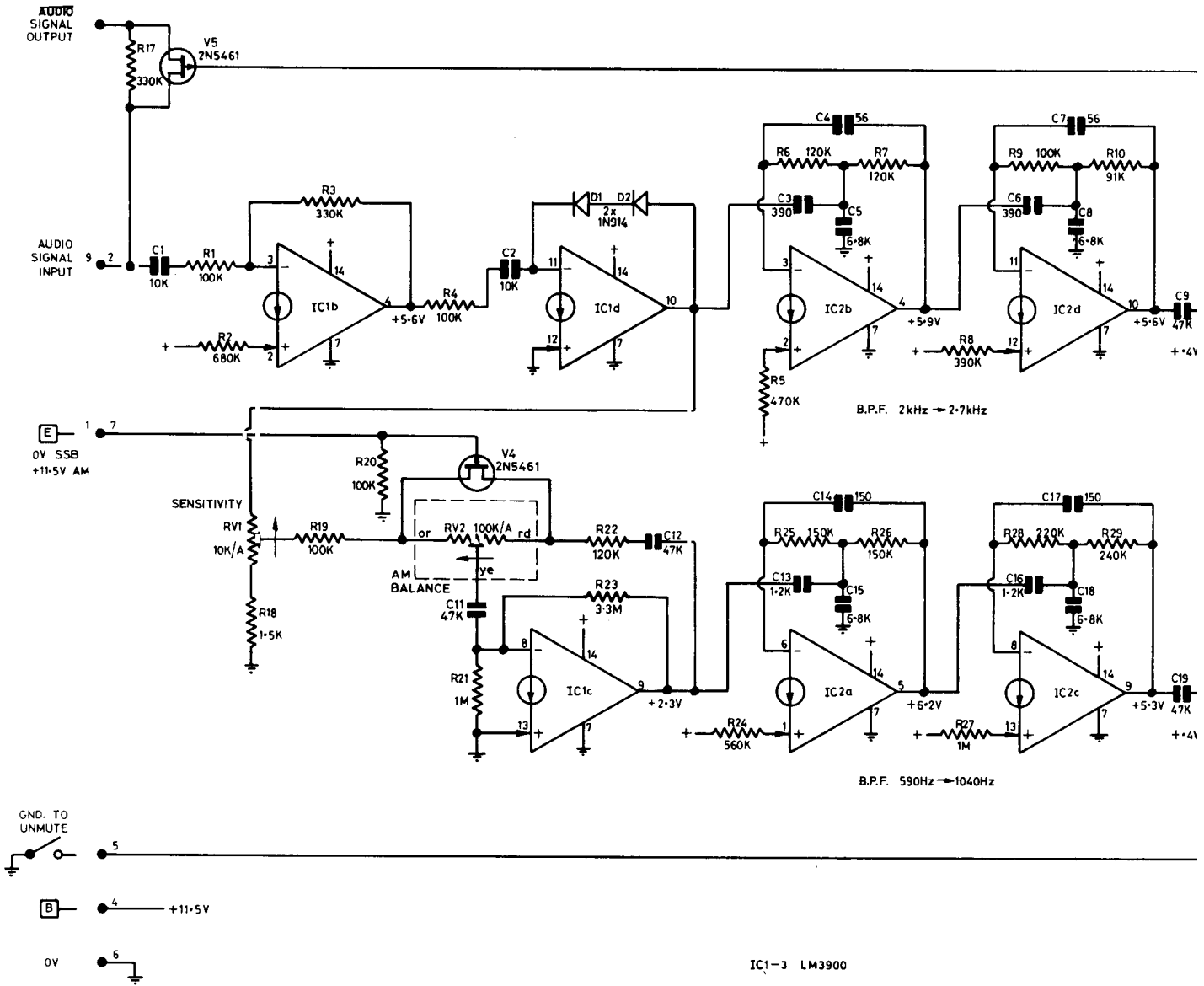

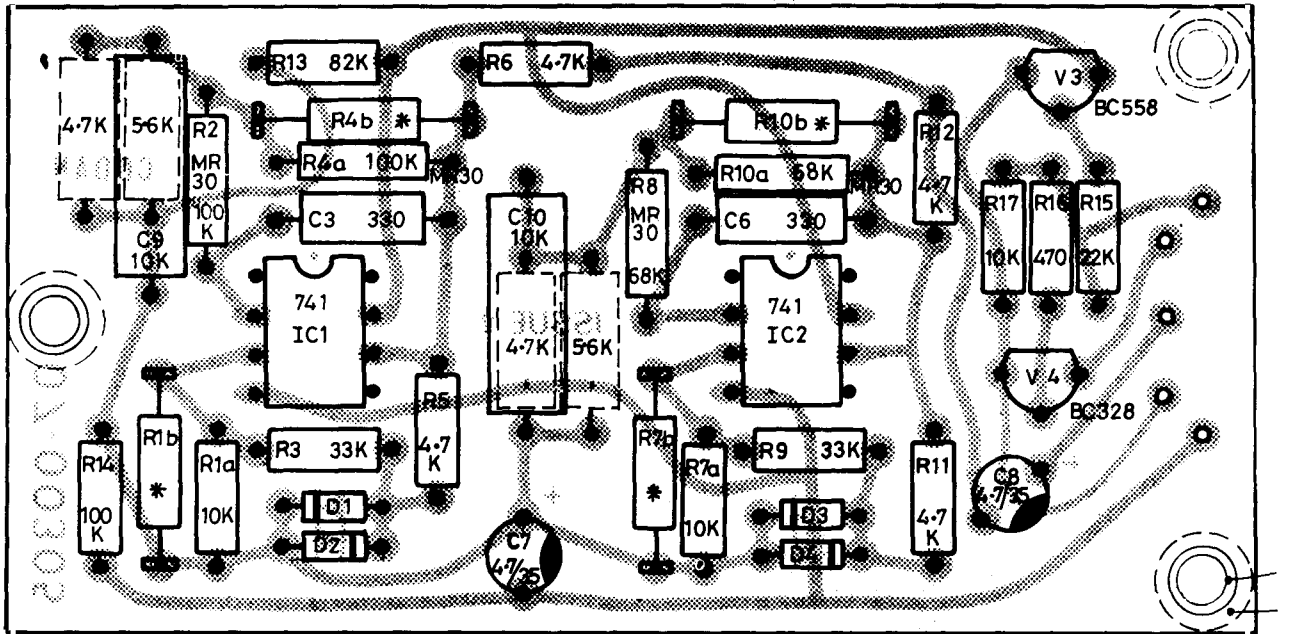

P.C.B. 07-00305 ISS. 2.

* SELECT ON TEST.
 R4a 100K NOM.
 R10a 68K NOM.